

**CHASSIS SECTION**

This service manual has been prepared to provide SUBARU service personnel with the necessary information and data for the correct maintenance and repair of SUBARU vehicles.

This manual includes the procedures for maintenance, disassembling, reassembling, inspection and adjustment of components and diagnostics for guidance of experienced mechanics.

Please peruse and utilize this manual fully to ensure complete repair work for satisfying our customers by keeping their vehicle in optimum condition. When replacement of parts during repair work is needed, be sure to use SUBARU genuine parts.

**FRONT SUSPENSION** FS

**REAR SUSPENSION** RS

**WHEEL AND TIRE SYSTEM** WT

**DIFFERENTIALS** DI

**TRANSFER CASE** TC

**DRIVE SHAFT SYSTEM** DS

**ABS** ABS

**BRAKE** BR

**PARKING BRAKE** PB

**POWER ASSISTED SYSTEM  
(POWER STEERING)** PS

**ABS (DIAGNOSTICS)** ABS

All information, illustration and specifications contained in this manual are based on the latest product information available at the time of publication approval.

# BRAKE

# BR

---

	Page
1. General Description.....	2
2. Front Brake Pad.....	20
3. Front Disc Rotor.....	22
4. Front Disc Brake Assembly.....	23
5. Rear Brake Pad.....	26
6. Rear Disc Rotor.....	27
7. Rear Disc Brake Assembly.....	29
8. Rear Drum Brake Shoe.....	32
9. Rear Drum Brake Drum.....	34
10. Rear Drum Brake Assembly.....	35
11. Master Cylinder.....	38
12. Brake Booster.....	40
13. Proportioning Valve.....	44
14. Brake Fluid.....	45
15. Air Bleeding.....	47
16. Brake Hose.....	49
17. Brake Pipe.....	50
18. Hill Holder.....	51
19. Brake Pedal.....	54
20. Stop Light Switch.....	60
21. General Diagnostics.....	62

# GENERAL DESCRIPTION

Brake

## 1. General Description S405001

### A: SPECIFICATIONS S405001E49

Engine (cc)		2000		
Driving system		AWD		
Model		Others	Non-TURBO Australia	TURBO
Front disc brake	Type	Disc (Floating type, ventilated)		
	Effective disc diameter	mm (in)	228 (8.98)	
	Disc thickness × Outer diameter	mm (in)	24 × 277 (0.94 × 10.91)	
	Effective cylinder diameter	mm (in)	42.8 (1.685) × 2	
	Pad dimensions (length × width × thickness*)	mm (in)	112.3 × 50.0 × 17.0 (4.42 × 1.969 × 0.669)	
	Clearance adjustment		Automatic adjustment	
Rear disc brake	Type	—	Disc (Floating type)	
	Effective disc diameter	mm (in)	—	230 (9.06)
	Disc thickness × Outer diameter	mm (in)	—	10 × 266 (0.39 × 10.47)
	Effective cylinder diameter	mm (in)	—	38.1 (1.500)
	Pad dimensions (length × width × thickness*)	mm (in)	—	82.4 × 33.7 × 14.0 (3.244 × 1.327 × 0.551)
	Clearance adjustment		—	Automatic adjustment
Rear drum brake	Type	Drum (Leading-Trailing type)		—
	Effective drum diameter	mm (in)	228.6 (9)	—
	Effective cylinder diameter	mm (in)	19.0 (0.748)	—
	Lining dimensions (length × width × thickness)	mm (in)	218.8 × 35.0 × 4.1 (8.61 × 1.378 × 0.161)	—
	Clearance adjustment		Automatic adjustment	—
Master cylinder	Type	Tandem		
	Effective diameter	mm (in)	26.99 (1-1/16)	
	Reservoir type	Sealed type		
	Brake fluid reservoir capacity	cm <sup>3</sup> (cu in)	205 (12.51)	
Brake booster	Type	Vacuum suspended		
	Effective diameter	mm (in)	205 + 230 (8.07 + 9.06)	
Proportioning valve	Split point	kPa (kg/cm <sup>2</sup> , psi)	3,678 (37.5, 533)	
	Reducing ratio		0.3	
Brake line	Dual circuit system			
ABS	OP		STD	
Brake fluid	FMVSS No. 116, DOT3 or DOT4			

\*: Including back metal

**NOTE:**

Refer to “PB section” for parking brake SPECIFICATIONS. <Ref. to PB-2, General Description.>

# GENERAL DESCRIPTION

Brake

ITEM		STANDARD	SERVICE LIMIT
Front brake	Pad thickness (including back metal)	17 mm (0.67 in)	7.5 mm (0.295 in)
	Disc thickness	24 mm (0.94 in)	22 mm (0.87 in)
	Disc runout	—	0.075 mm (0.0030 in)
Rear brake (Disc type)	Pad thickness (including back metal)	14 mm (0.55 in)	6.5 mm (0.256 in)
	Disc thickness	10 mm (0.39 in)	8.5 mm (0.335 in)
	Disc runout	—	0.070 mm (0.0028 in)
Rear brake (Drum type)	Inside diameter	228.6 mm (9 in)	230.6 mm (9.08 in)
	Lining thickness	4.1 mm (0.161 in)	1.5 mm (0.059 in)
Rear brake (Disc type parking)	Inside diameter	170 mm (6.69 in)	171 mm (6.73 in)
	Lining thickness	3.2 mm (0.126 in)	1.5 mm (0.059 in)
Parking brake	Lever stroke	7 to 8 notches/196 N (20 kgf, 44 lb)	

Brake booster		Brake pedal force	Fluid pressure
		Brake fluid pressure without engine running	147 N (15 kgf, 33 lb) 294 N (30 kgf, 66 lb)
Brake fluid pressure with engine running and vacuum at 66.7 kPa (500 mmHg, 19.69 inHg)		147 N (15 kgf, 33 lb) 294 N (30 kgf, 66 lb)	5,394 kPa (55 kg/cm <sup>2</sup> , 782 psi) 10,003 kPa (102 kg/cm <sup>2</sup> , 1,450 psi)

Brake pedal	Free play	1 — 3 mm (0.04 — 0.12 in) [Depress brake pedal pad with a force of less than 10 N (1 kgf, 2 lb).]
-------------	-----------	------------------------------------------------------------------------------------------------------

# GENERAL DESCRIPTION

Brake

## B: COMPONENT S405001A05

### 1. FRONT DISC BRAKE S405001A0511

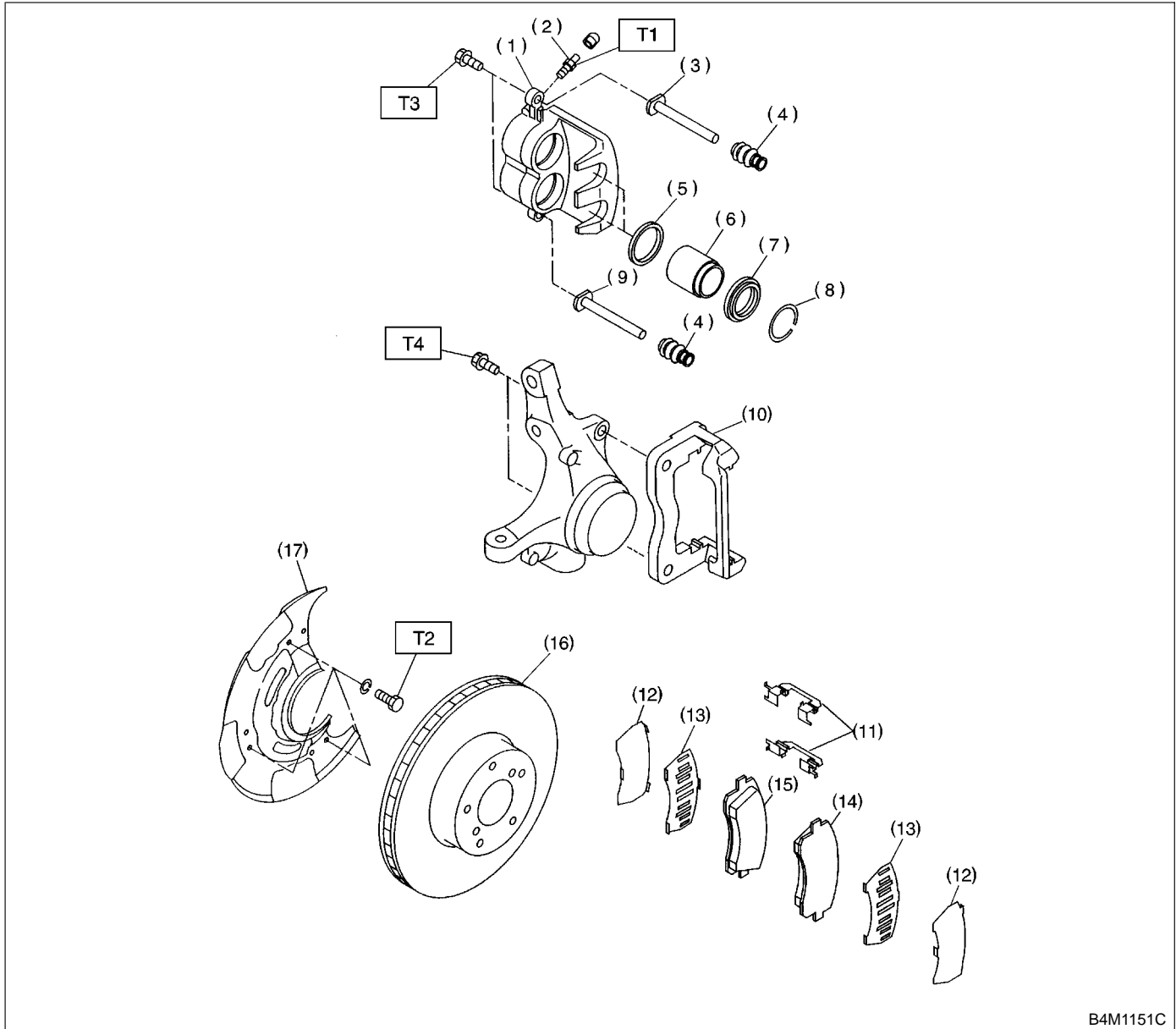

B4M1151C

- (1) Caliper body
- (2) Air bleeder screw
- (3) Guide pin (Green)
- (4) Pin boot
- (5) Piston seal
- (6) Piston
- (7) Piston boot
- (8) Boot ring

- (9) Lock pin (Yellow)
- (10) Support
- (11) Pad clip
- (12) Outer shim (For Australia)
- (13) Inner shim (For Australia)
- (14) Pad (Outside)
- (15) Pad (Inside)
- (16) Disc rotor

- (17) Disc cover

**Tightening torque: N·m (kgf·m, ft·lb)**

**T1: 8 (0.8, 5.8)**

**T2: 18 (1.8, 13.0)**

**T3: 39 (4.0, 28.9)**

**T4: 78 (8.0, 58)**

## 2. REAR DISC BRAKE S405001A0503

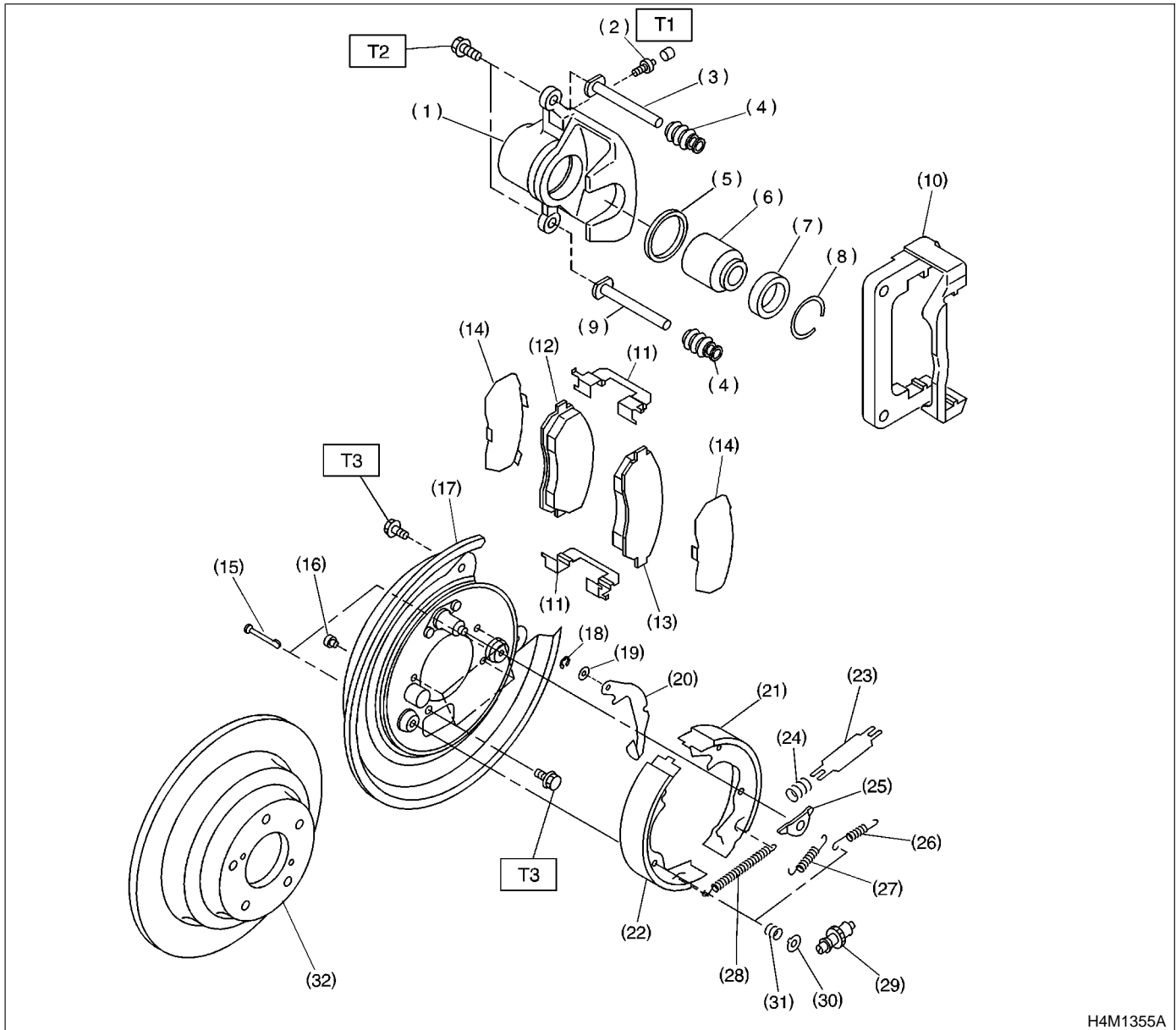

H4M1355A

- |                       |                                     |                                 |
|-----------------------|-------------------------------------|---------------------------------|
| (1) Caliper body      | (14) Shim                           | (27) Primary shoe return spring |
| (2) Air bleeder screw | (15) Shoe hold-down pin             | (28) Adjusting spring           |
| (3) Guide pin (Green) | (16) Cover                          | (29) Adjuster                   |
| (4) Pin boot          | (17) Back plate                     | (30) Shoe hold-down cup         |
| (5) Piston seal       | (18) Retainer                       | (31) Shoe hold-down spring      |
| (6) Piston            | (19) Spring washer                  | (32) Disc rotor                 |
| (7) Piston boot       | (20) Parking brake lever            |                                 |
| (8) Boot ring         | (21) Parking brake shoe (Secondary) |                                 |
| (9) Lock pin (Yellow) | (22) Parking brake shoe (Primary)   |                                 |
| (10) Support          | (23) Strut                          |                                 |
| (11) Pad clip         | (24) Strut shoe spring              |                                 |
| (12) Inner pad        | (25) Shoe guide plate               |                                 |
| (13) Outer pad        | (26) Secondary shoe return spring   |                                 |

**Tightening torque: N·m (kgf·m, ft·lb)**

**T1: 8 (0.8, 5.8)**

**T2: 39 (4.0, 28.9)**

**T3: 52 (5.3, 38.3)**

# GENERAL DESCRIPTION

Brake

## 3. REAR DRUM BRAKE S405001A0504

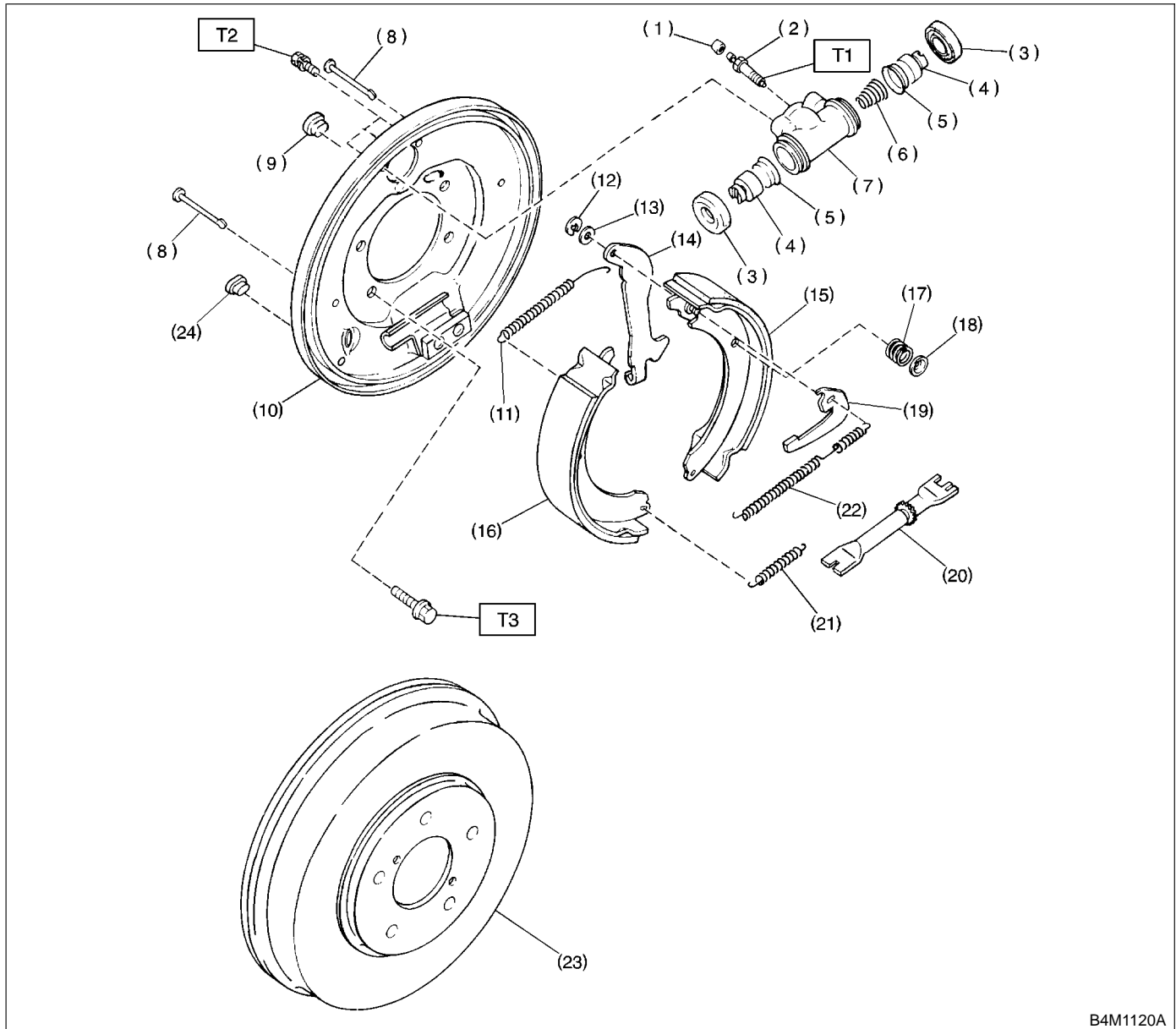

B4M1120A

- |                         |                               |                               |
|-------------------------|-------------------------------|-------------------------------|
| (1) Air bleeder cap     | (11) Upper shoe return spring | (21) Lower shoe return spring |
| (2) Air bleeder screw   | (12) Retainer                 | (22) Adjusting spring         |
| (3) Boot                | (13) Washer                   | (23) Drum                     |
| (4) Piston              | (14) Parking brake lever      | (24) Plug                     |
| (5) Cup                 | (15) Brake shoe (Trailing)    |                               |
| (6) Spring              | (16) Brake shoe (Leading)     |                               |
| (7) Wheel cylinder body | (17) Shoe hold-down spring    |                               |
| (8) Pin                 | (18) Cup                      |                               |
| (9) Plug                | (19) Adjusting lever          |                               |
| (10) Back plate         | (20) Adjuster                 |                               |

---

**Tightening torque: N·m (kgf·m, ft·lb)**

**T1: 8 (0.8, 5.8)**

**T2: 10 (1.0, 7.2)**

**T3: 52 (5.3, 38.3)**

---

## 4. MASTER CYLINDER S405001A0505

### ● LHD model

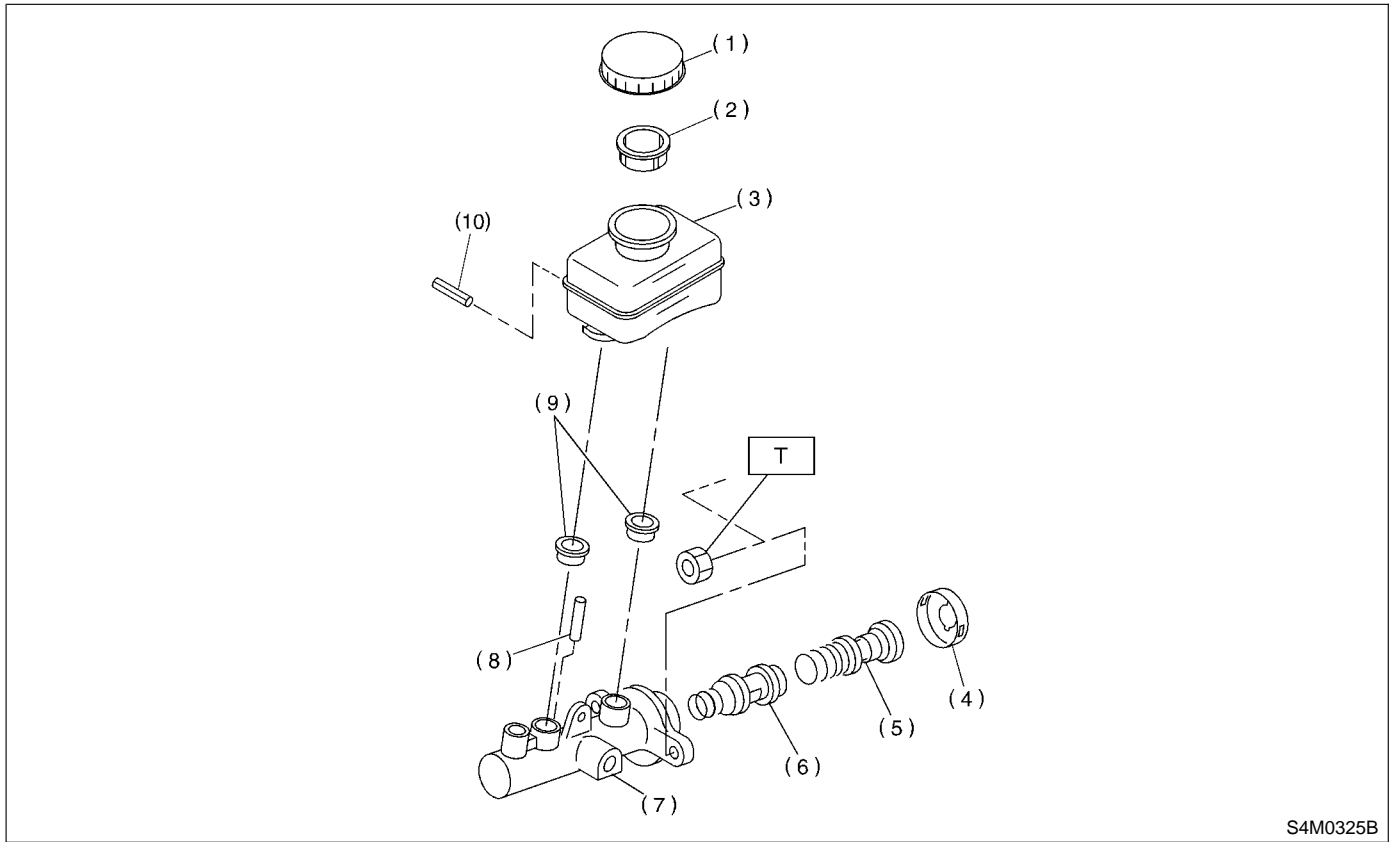

- |                     |                             |
|---------------------|-----------------------------|
| (1) Cap             | (6) Secondary piston        |
| (2) Filter          | (7) Cylinder body           |
| (3) Reservoir tank  | (8) Cylinder pin (With ABS) |
| (4) Piston retainer | (9) Seal                    |
| (5) Primary piston  | (10) Pin                    |

**Tightening torque: N·m (kgf·m, ft·lb)**  
**T: 14 (1.4, 10.1)**



# GENERAL DESCRIPTION

Brake

## ● RHD model

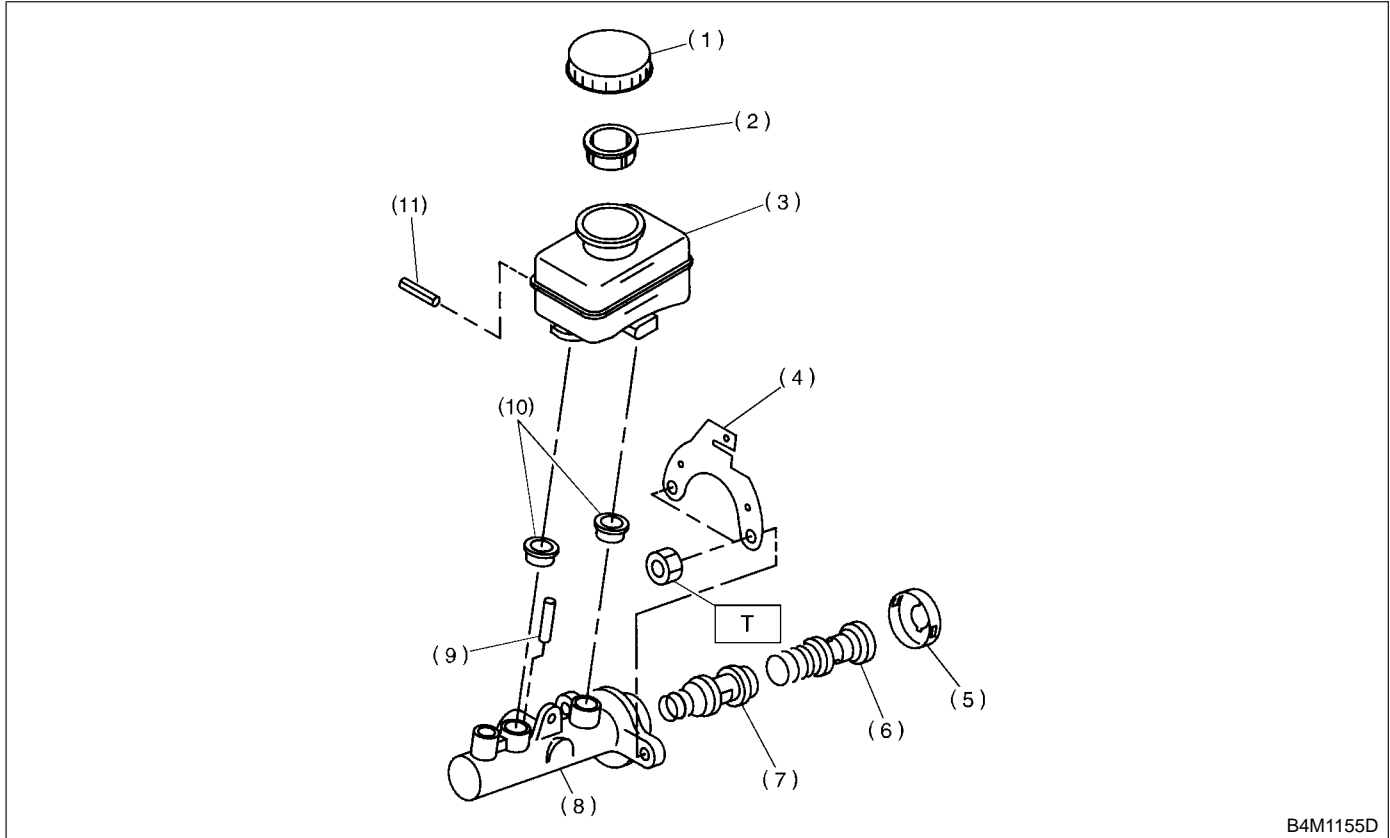

- (1) Cap
- (2) Filter
- (3) Reservoir tank
- (4) Bracket
- (5) Piston retainer
- (6) Primary piston
- (7) Secondary piston
- (8) Cylinder body
- (9) Cylinder pin (With ABS)
- (10) Seal

(11) Pin

**Tightening torque: N·m (kgf·m, ft·lb)**

**T: 14 (1.4, 10.1)**

5. HILL HOLDER S405001A0510

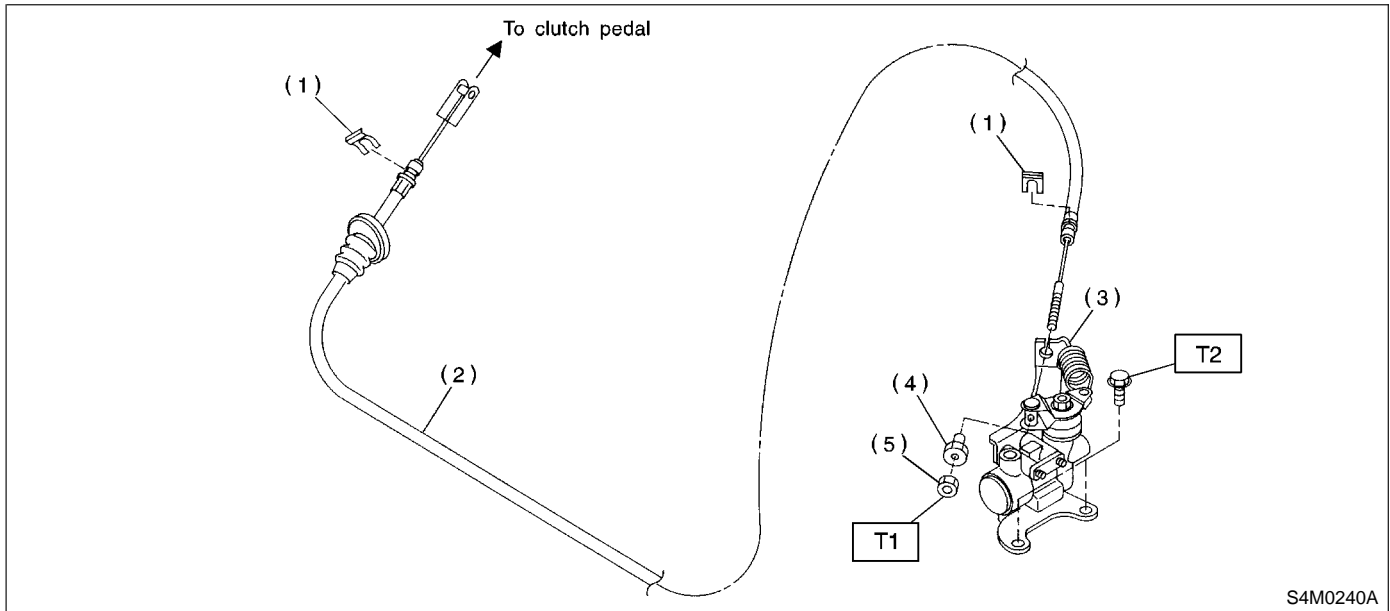

- (1) Clamp
- (2) PHV cable
- (3) PHV (Pressure hold valve)
- (4) Adjusting nut

- (5) Lock nut

**Tightening torque: N·m (kgf·m, ft·lb)**

**T1: 3.5 (0.35, 2.5)**

**T2: 18 (1.8, 13.0)**

# GENERAL DESCRIPTION

Brake

## 6. BRAKE PIPES AND HOSE S405001A0506

### ● Front brake pipe for model with ABS (LHD)

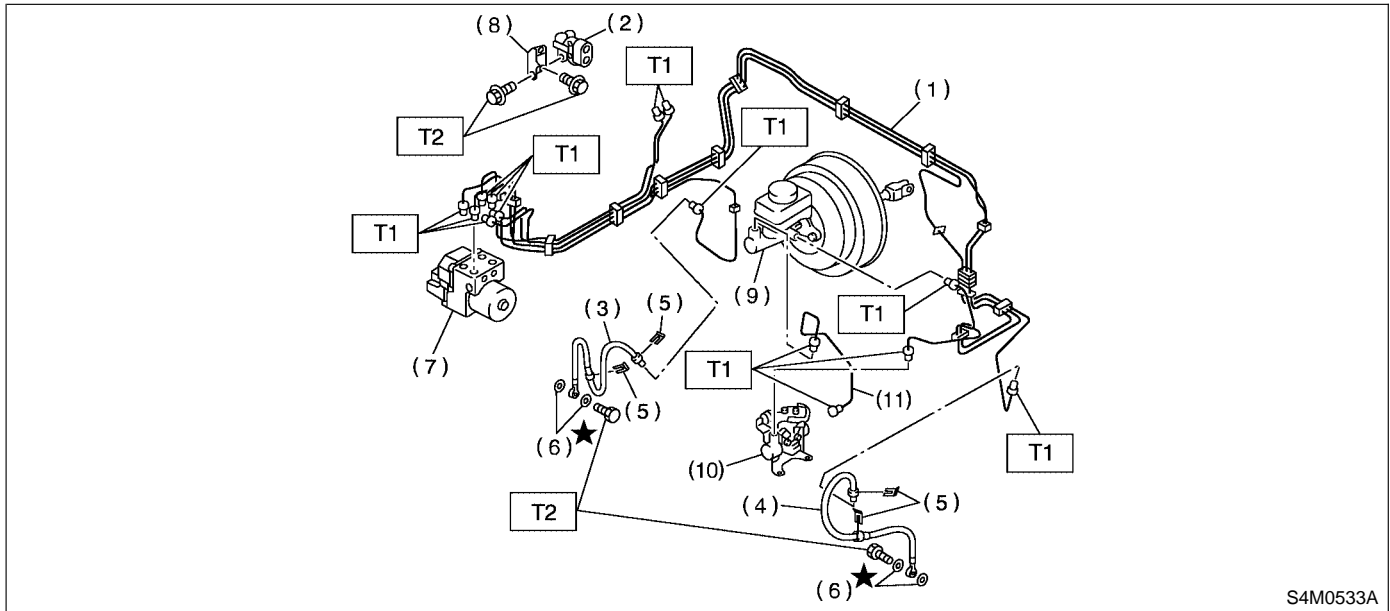

S4M0533A

- |                               |                                                   |
|-------------------------------|---------------------------------------------------|
| (1) Front brake pipe assembly | (7) ABS control module and hydraulic control unit |
| (2) Proportioning valve       | (8) Bracket                                       |
| (3) Front brake hose RH       | (9) Master cylinder                               |
| (4) Front brake hose LH       | (10) Hill holder                                  |
| (5) Clamp                     | (11) Adapter pipe                                 |
| (6) Gasket                    |                                                   |

**Tightening torque: N·m (kgf·m, ft·lb)**

**T1: 15 (1.5, 10.8)**

**T2: 18 (1.8, 13.0)**

### ● Front brake pipe for model with ABS (RHD)

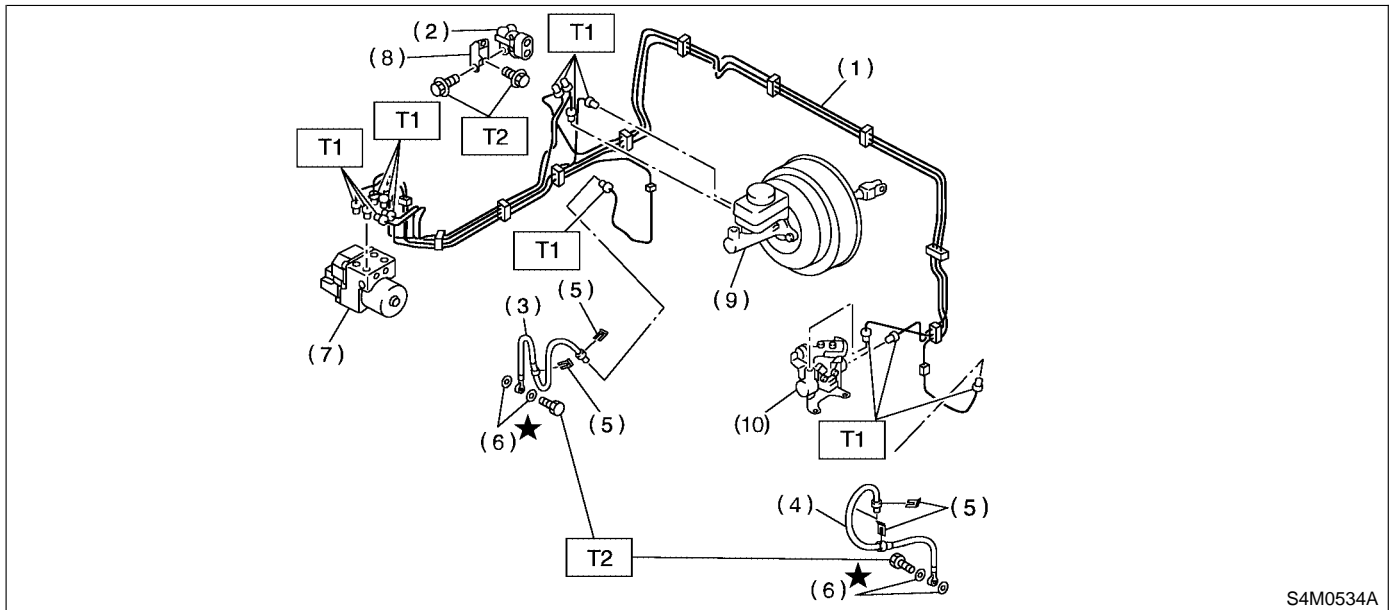

S4M0534A

- |                               |                                                   |
|-------------------------------|---------------------------------------------------|
| (1) Front brake pipe assembly | (7) ABS control module and hydraulic control unit |
| (2) Proportioning valve       | (8) Bracket                                       |
| (3) Front brake hose RH       | (9) Master cylinder                               |
| (4) Front brake hose LH       | (10) Hill holder                                  |
| (5) Clamp                     | (11) Adapter pipe                                 |
| (6) Gasket                    |                                                   |

**Tightening torque: N·m (kgf·m, ft·lb)**

**T1: 15 (1.5, 10.8)**

**T2: 18 (1.8, 13.0)**

## ● Front brake pipe for model without ABS (LHD)

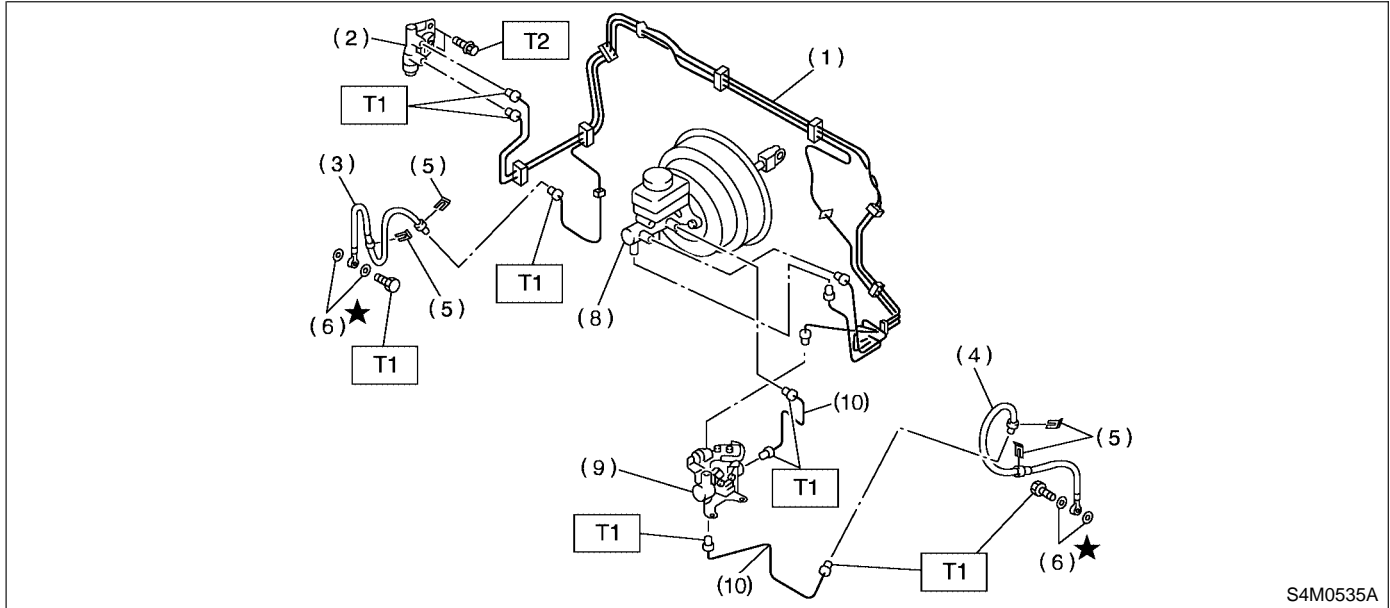

S4M0535A

- (1) Front brake pipe assembly
- (2) Proportioning valve
- (3) Front brake hose RH
- (4) Front brake hose LH
- (5) Clamp

- (6) Gasket
- (7) Bracket
- (8) Master cylinder
- (9) Hill holder
- (10) Adapter pipe

**Tightening torque: N·m (kgf·m, ft·lb)**

**T1: 15 (1.5, 10.8)**

**T2: 18 (1.8, 13.0)**

## ● Front brake pipe for model without ABS (RHD)

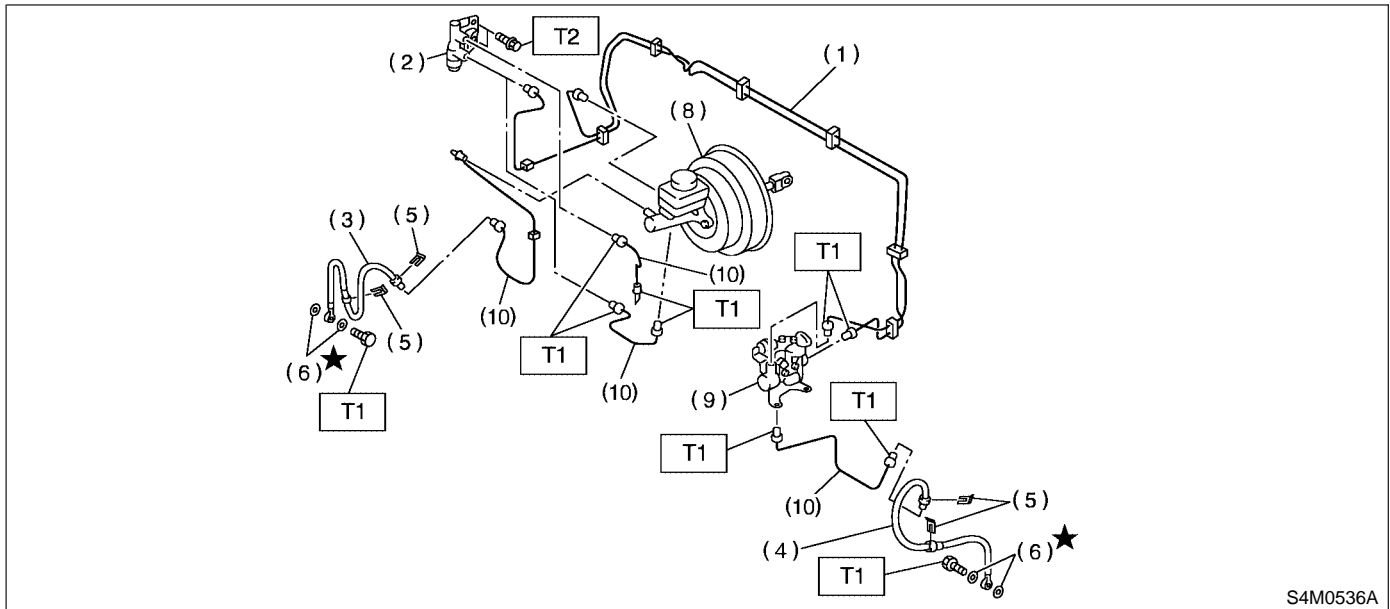

S4M0536A

- (1) Front brake pipe assembly
- (2) Proportioning valve
- (3) Front brake hose RH
- (4) Front brake hose LH
- (5) Clamp

- (6) Gasket
- (7) Bracket
- (8) Master cylinder
- (9) Hill holder
- (10) Adapter pipe

**Tightening torque: N·m (kgf·m, ft·lb)**

**T1: 15 (1.5, 10.8)**

**T2: 18 (1.8, 13.0)**

# GENERAL DESCRIPTION

Brake

## ● Center and rear brake pipe

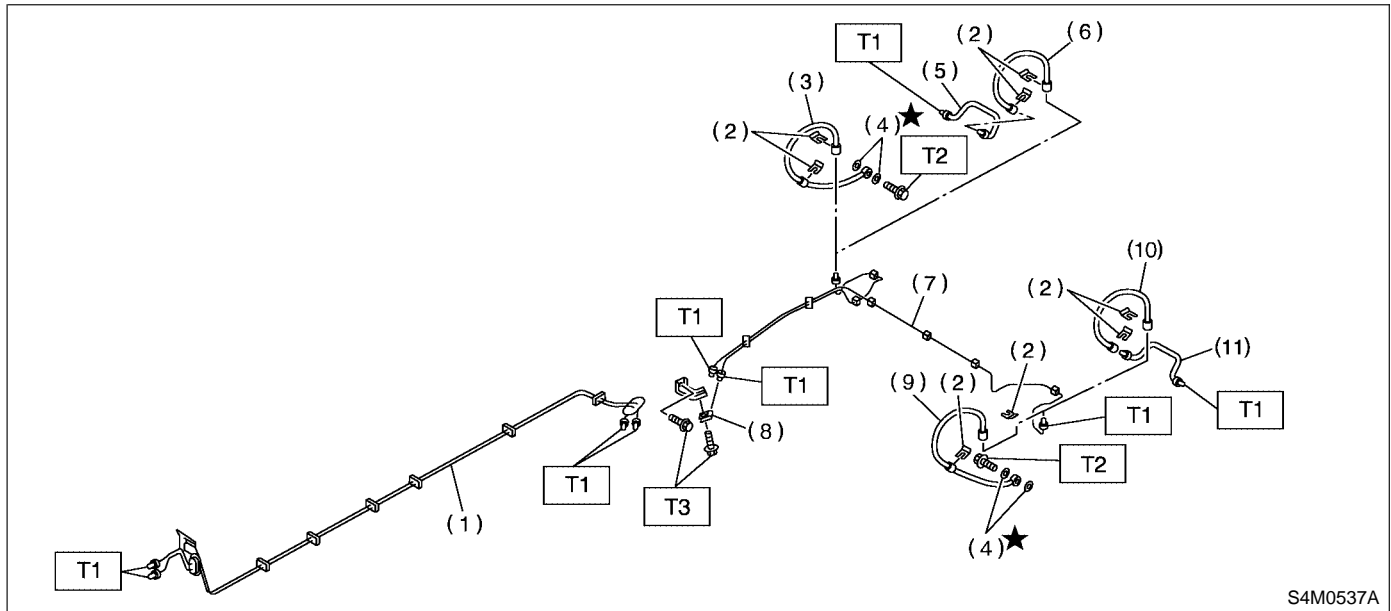

- (1) Center brake pipe assembly
- (2) Clamp
- (3) Rear brake hose RH (With ABS)
- (4) Gasket
- (5) Rear brake pipe RH (Without ABS)
- (6) Rear brake hose RH (Without ABS)
- (7) Rear brake pipe assembly
- (8) Two-way connector
- (9) Rear brake hose LH (With ABS)
- (10) Rear brake hose LH (Without ABS)
- (11) Rear brake pipe LH (Without ABS)

**Tightening torque: N·m (kgf·m, ft·lb)**

**T1: 15 (1.5, 10.8)**

**T2: 18 (1.8, 13.0)**

**T3: 32 (3.3, 23.6)**

## 7. BRAKE BOOSTER S405001A0507

### ● LHD model

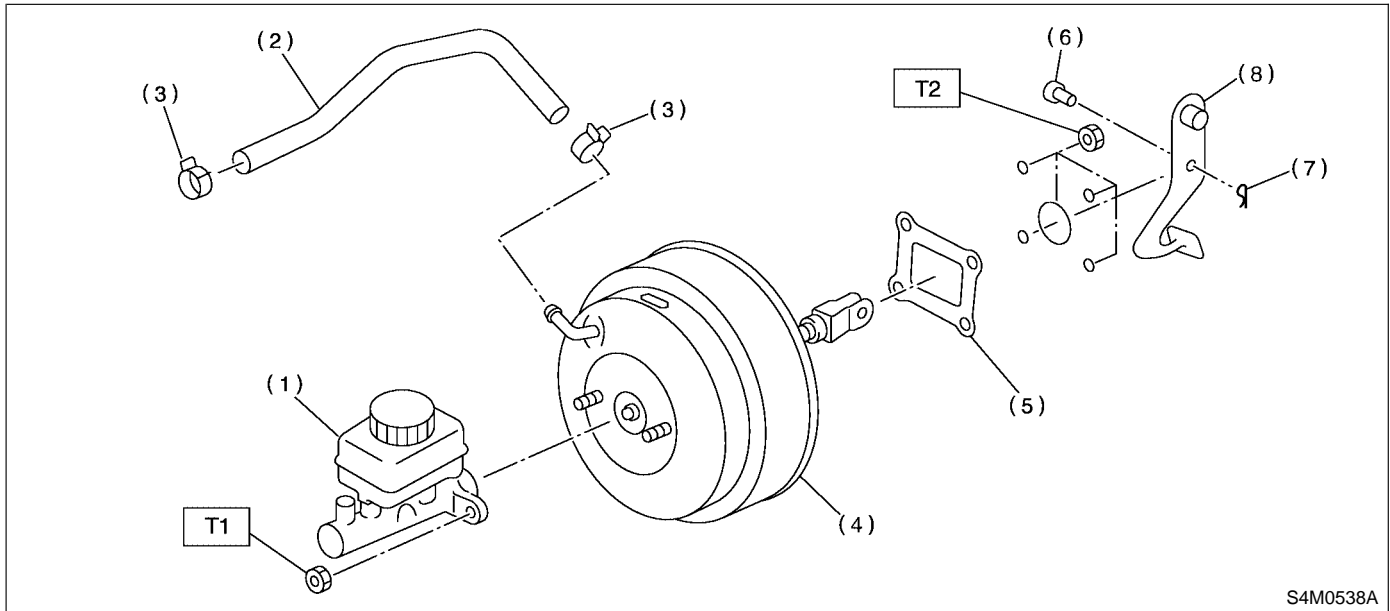

### ● RHD model

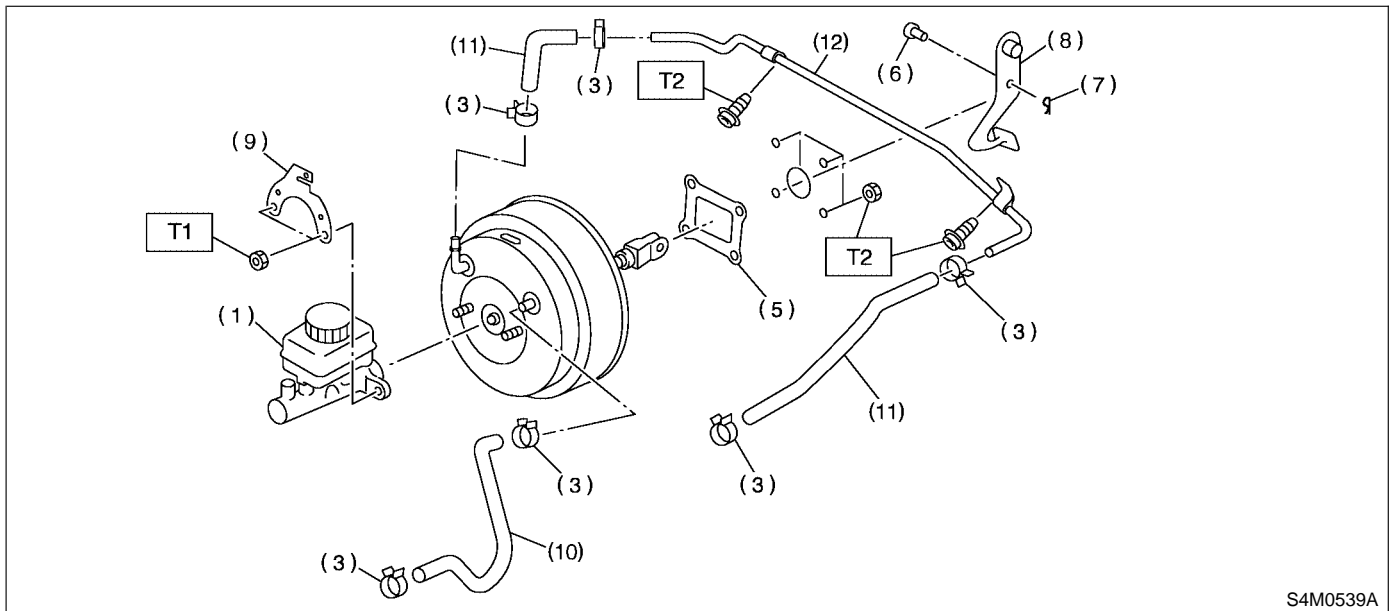

- |                            |                                    |
|----------------------------|------------------------------------|
| (1) Brake master cylinder  | (7) Snap pin                       |
| (2) Vacuum hose            | (8) Brake pedal                    |
| (3) Clip                   | (9) Bracket                        |
| (4) Brake booster assembly | (10) Vacuum hose (Non-turbo model) |
| (5) Seal                   | (11) Vacuum hose (Turbo model)     |
| (6) Clevis pin             | (12) Vacuum pipe (Turbo model)     |

**Tightening torque: N·m (kgf·m, ft·lb)**

**T1: 14 (1.4, 10.1)**

**T2: 18 (1.8, 13.0)**

# GENERAL DESCRIPTION

Brake

## 8. BRAKE PEDAL FOR MT MODEL S405001A0508

### ● LHD model

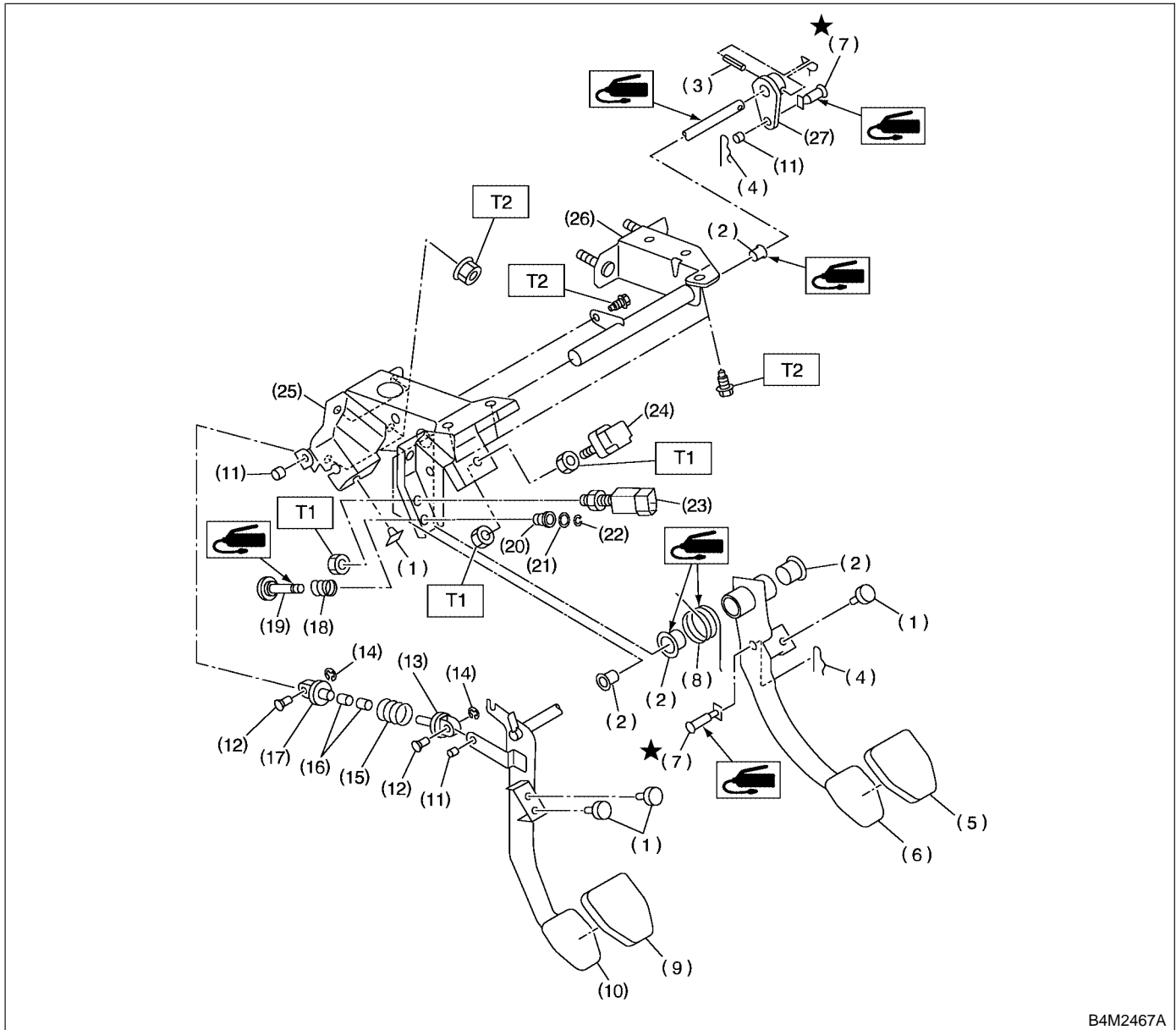

B4M2467A

- |                        |                        |                                          |
|------------------------|------------------------|------------------------------------------|
| (1) Stopper            | (12) Clutch clevis pin | (23) Clutch switch (With cruise control) |
| (2) Bushing            | (13) Assist rod A      | (24) Stop light switch                   |
| (3) Spring pin         | (14) Clip              | (25) Pedal bracket                       |
| (4) Snap pin           | (15) Assist spring     | (26) Clutch master cylinder bracket      |
| (5) Brake pedal pad    | (16) Assist bushing    | (27) Lever                               |
| (6) Brake pedal        | (17) Assist rod B      |                                          |
| (7) Clevis pin         | (18) Spring S          |                                          |
| (8) Brake pedal spring | (19) Rod S             |                                          |
| (9) Clutch pedal pad   | (20) Bushing S         |                                          |
| (10) Clutch pedal      | (21) O-ring            |                                          |
| (11) Bushing C         | (22) Clip              |                                          |

**Tightening torque: N·m (kgf·m, ft·lb)**

**T1: 8 (0.8, 5.8)**

**T2: 18 (1.8, 13.0)**

● RHD model

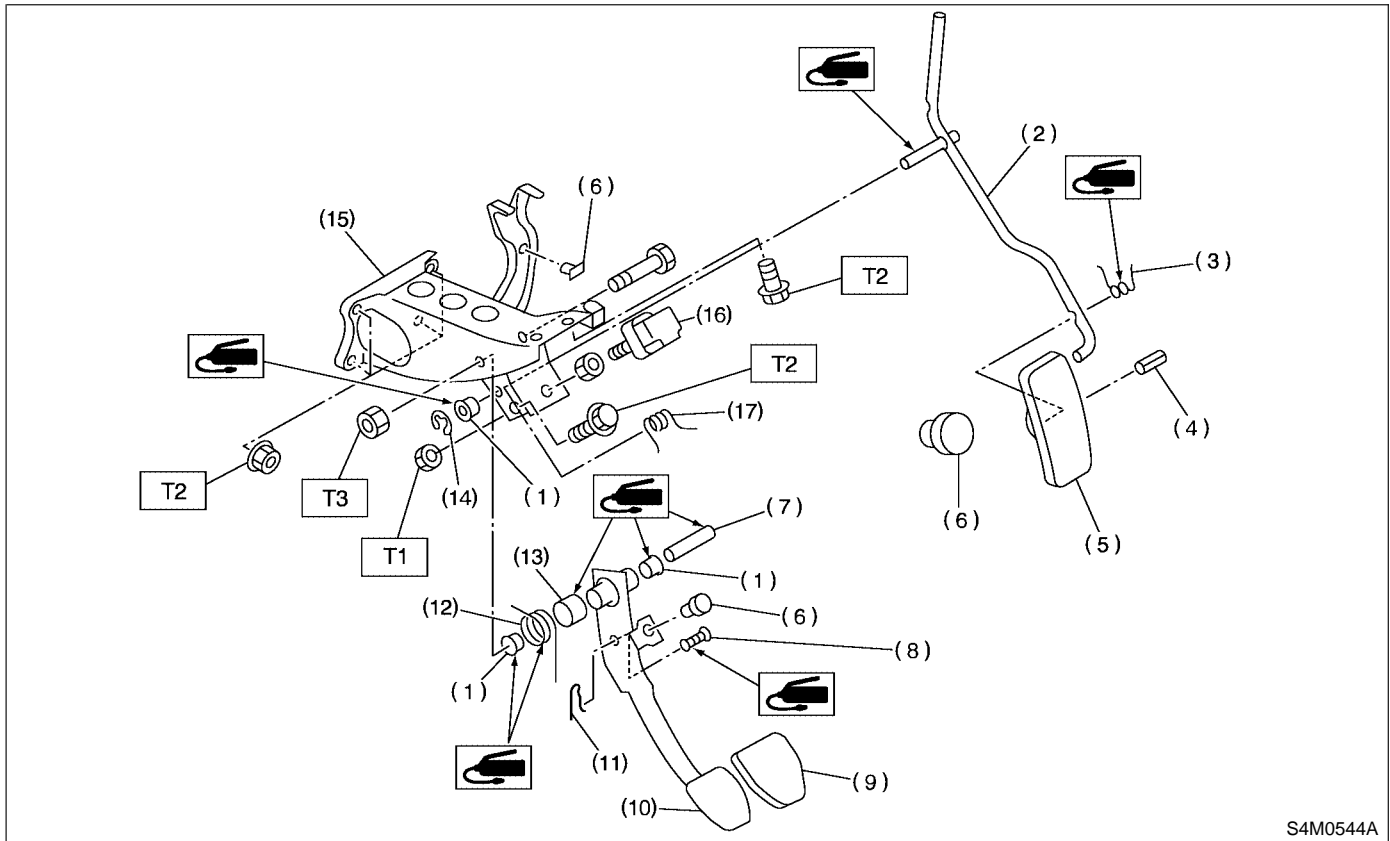

- (1) Bushing
- (2) Accelerator pedal
- (3) Accelerator pedal spring
- (4) Spring pin
- (5) Accelerator pedal pad
- (6) Stopper
- (7) Spacer
- (8) Clevis pin

- (9) Brake pedal pad
- (10) Brake pedal
- (11) Snap pin
- (12) Brake pedal spring
- (13) Brake spacer
- (14) Clip
- (15) Pedal bracket
- (16) Stop light switch

- (17) Accelerator spring

**Tightening torque: N·m (kgf·m, ft·lb)**

**T1: 8 (0.8, 5.8)**

**T2: 18 (1.8, 13.0)**

**T3: 29 (3.0, 21.7)**



# GENERAL DESCRIPTION

Brake

## 9. BRAKE PEDAL FOR AT MODEL S405001A0509

### ● LHD model

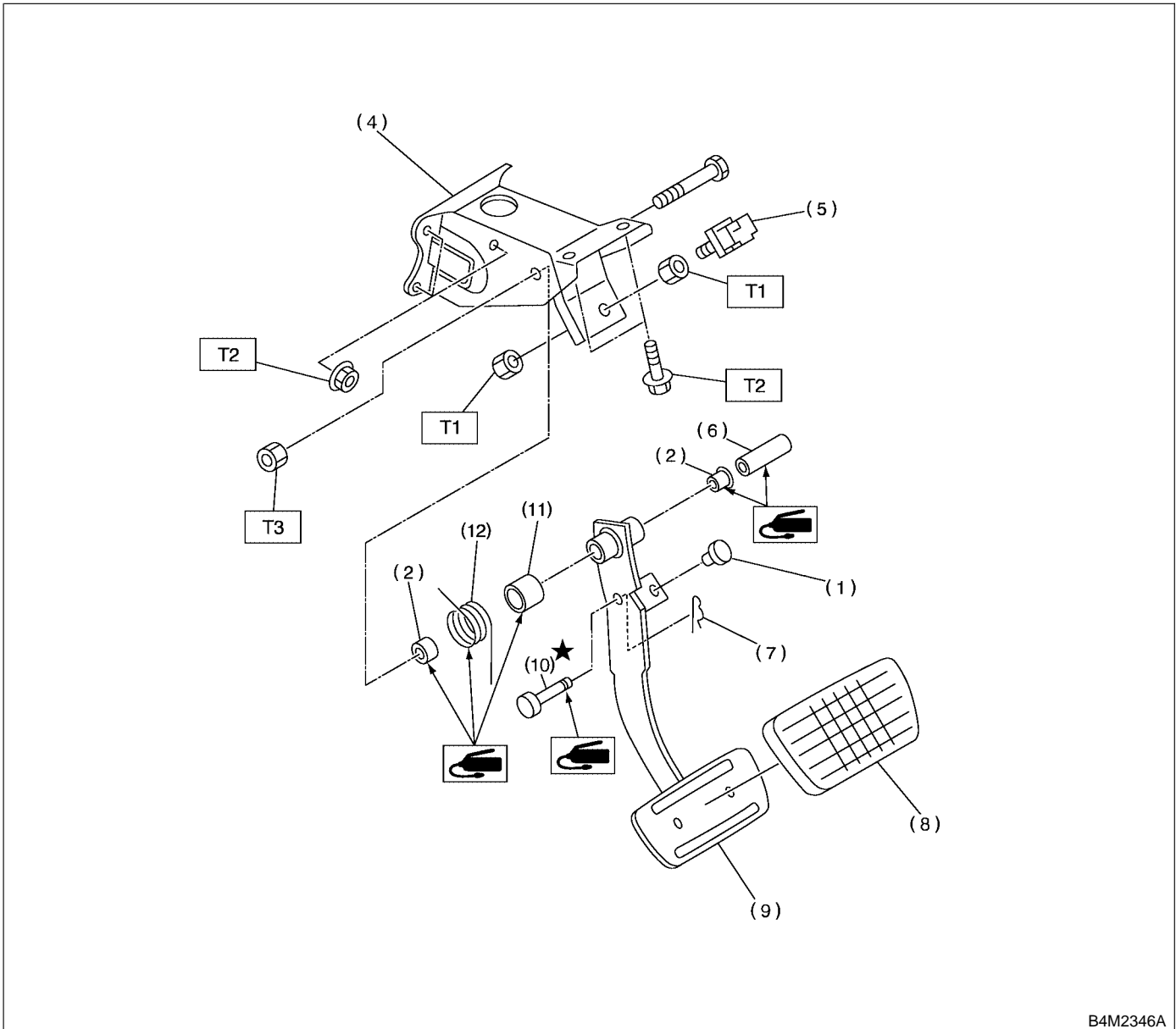

- (1) Stopper
- (2) Bushing
- (3) Plug
- (4) Pedal bracket
- (5) Stop light switch
- (6) Spacer

- (7) Snap pin
- (8) Brake pedal pad
- (9) Brake pedal
- (10) Clevis pin
- (11) Brake spacer
- (12) Brake pedal spring

**Tightening torque: N·m (kgf·m, ft·lb)**

**T1: 8 (0.8, 5.8)**

**T2: 18 (1.8, 13.0)**

**T3: 30 (3.1, 22.4)**

● RHD model

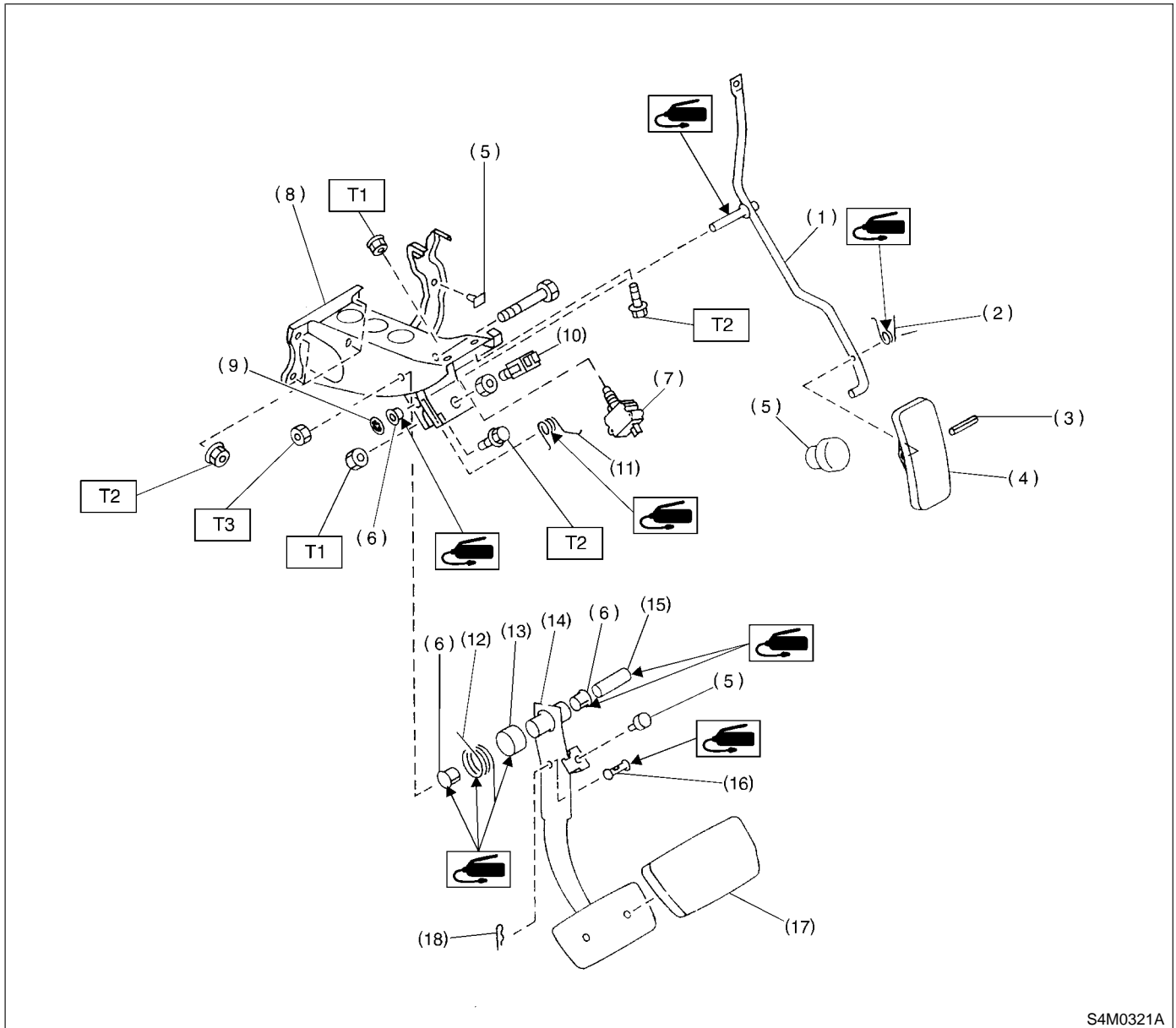

S4M0321A

- (1) Accelerator pedal
- (2) Accelerator pedal spring
- (3) Spring pin
- (4) Accelerator pedal pad
- (5) Stopper
- (6) Bushing
- (7) Kick-down switch
- (8) Pedal bracket

- (9) Clip
- (10) Stop light switch
- (11) Accelerator spring
- (12) Brake pedal spring
- (13) Brake spacer
- (14) Brake pedal
- (15) Spacer
- (16) Clevis pin

- (17) Brake pedal pad
- (18) Snap pin

**Tightening torque: N·m (kgf·m, ft·lb)**

**T1: 8 (0.8, 5.8)**

**T2: 18 (1.8, 13.0)**

**T3: 29 (3.0, 21.7)**

### **C: CAUTION** S405001A03

- Wear working clothing, including a cap, protective goggles, and protective shoes during operation.
- Remove contamination including dirt and corrosion before removal, installation or disassembly.
- Keep the disassembled parts in order and protect them from dust or dirt.
- Before removal, installation or disassembly, be sure to clarify the failure. Avoid unnecessary removal, installation, disassembly, and replacement.
- Be careful not to burn your hands, because each part in the vehicle is hot after running.
- Use SUBARU genuine grease etc. or the equivalent. Do not mix grease etc. with that of another grade or from other manufacturers.
- Be sure to tighten fasteners including bolts and nuts to the specified torque.
- Place shop jacks or safety stands at the specified points.
- Apply grease onto sliding or revolution surfaces before installation.
- Before installing O-rings or snap rings, apply sufficient amount of grease to avoid damage and deformation.
- Before securing a part on a vise, place cushioning material such as wood blocks, aluminum plate, or shop cloth between the part and the vise.
- Do not put fluid on body. If the body is tainted, wash away with water.

# GENERAL DESCRIPTION

Brake

## D: PREPARATION TOOL S405001A17

### 1. SPECIAL TOOLS S405001A1701

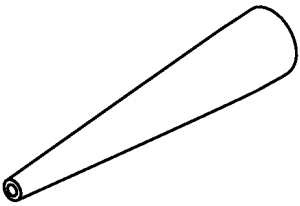
ILLUSTRATION	TOOL NUMBER	DESCRIPTION	REMARKS
  <p style="text-align: right;"><small>B4M2406</small></p>	926460000	WHEEL CYLINDER 3/4" ADAPTER	Used for installing cup onto wheel cylinder piston (Size 3/4 in).

### 2. GENERAL PURPOSE TOOLS S405001A1702

TOOL NAME	REMARKS
Snap Ring Pliers	Used for removing and installing snap ring.

# FRONT BRAKE PAD

Brake

## 2. Front Brake Pad S405178

### A: REMOVAL S405178A18

- 1) Loosen wheel nuts, jack-up vehicle, support it with safety stands, and remove wheel.
- 2) Remove lock pin.
- 3) Raise caliper body.
- 4) Remove pad.

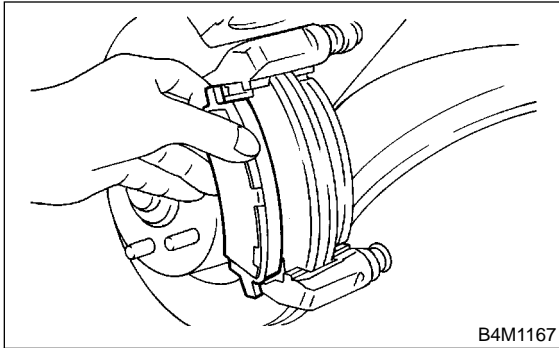

#### NOTE:

If brake pad is difficult to remove, proceed as follows:

- (1) Remove caliper body and fasten it provisionally to coil spring.
- (2) Remove support.
- (3) Place a support in a vise between wooden blocks.

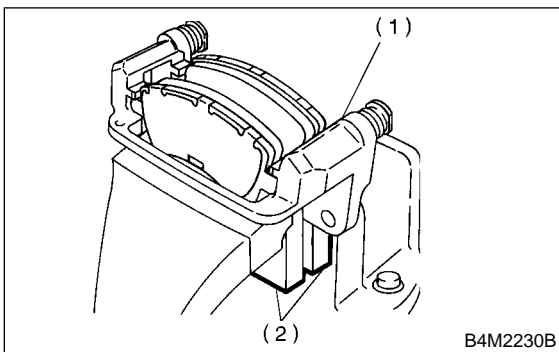

- (1) Support
- (2) Wooden blocks

- (4) Attach a rod of less than 12 mm (0.47 in) dia. to the shaded area of brake pad, and strike the rod with a hammer to drive brake pad out of place.

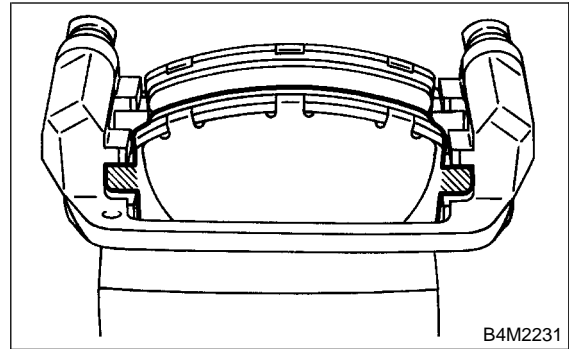

### B: INSTALLATION S405178A11

- 1) Apply thin coat of Molykote AS880N (Part No. 26298AC000) to the frictional portion between pad and pad clip.
- 2) Apply thin coat of Molykote AS880N (Part No. 26298AC000) to the frictional portion between pad and pad inner shim. (Australia model)

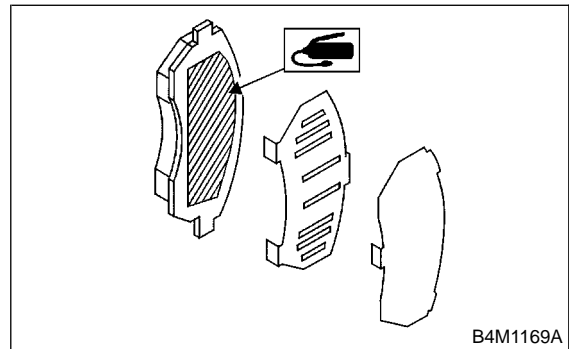

- 3) Install pads on support.
- 4) Install caliper body on support.

#### Tightening torque:

**39 N·m (4.0 kgf·m, 28.9 ft·lb)**

#### NOTE:

If it is difficult to push piston during pad replacement, loosen air bleeder to facilitate work.

**C: INSPECTION** S405178A10

Check pad thickness A.

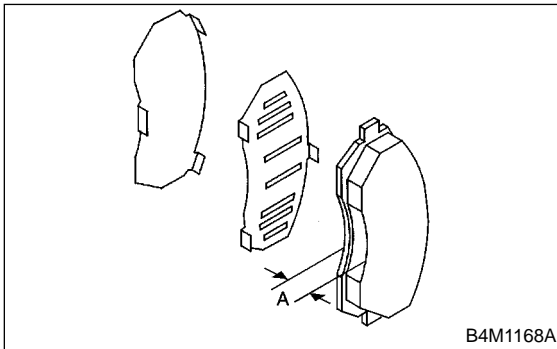

Pad thickness (including back metal)	Standard value	17 mm (0.67 in)
	Wear limit	7.5 mm (0.295 in)

**CAUTION:**

- Always replace the pads for both the left and right wheels at the same time. Also replace pad clips if they are twisted or worn.
- A wear indicator is provided on the inner disc brake pad. If the pad wears down to such an extent that the end of the wear indicator contacts the disc rotor, a squeaking sound is produced as the wheel rotates. If this sound is heard, replace the pad.
- Replace pad if there is oil or grease on it.

# FRONT DISC ROTOR

Brake

## 3. Front Disc Rotor S405173

### A: REMOVAL S405173A18

- 1) Loosen wheel nuts, jack-up vehicle, support it with safety stands, and remove wheel.
- 2) Remove caliper body from housing, and suspend it from strut using a wire.

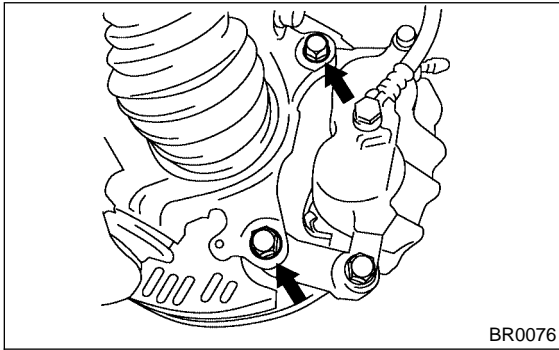

- 3) Remove the disc rotor.

#### NOTE:

If disc rotor seizes up within the hub, drive disc rotor out by installing an 8-mm bolt in holes B on the rotor.

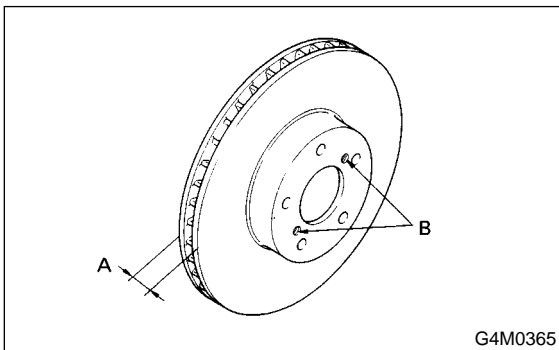

- 4) Clean mud and foreign particles from caliper body assembly and support.

### B: INSTALLATION S405173A11

- 1) Install the disc rotor.
- 2) Install the caliper body to housing.

#### Tightening torque:

**78 N·m (8 kgf-m, 58 ft-lb)**

### C: INSPECTION S405173A10

- 1) Install disc rotor by tightening the five wheel nuts.
- 2) Set a dial gauge on the disc rotor. Turn disc rotor to check runout.

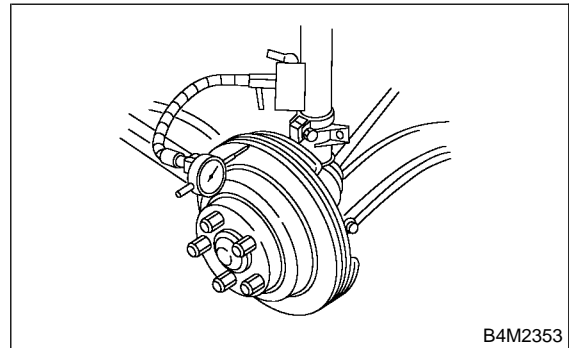

#### NOTE:

- Make sure that dial gauge is set 5 mm (0.20 in) inward of rotor outer perimeter.
- If disc rotor runout is above standard value, inspect play of hub bearing axial direction and runout of axle hub. <Ref. to DS-22, INSPECTION, Front Axle.>

If bearing and hub are normal, replace disc rotor.

#### Disc rotor runout limit:

**0.075 mm (0.0030 in)**

- 3) Measure disc rotor thickness.

If thickness of disc rotor is outside the standard value, replace disc rotor.

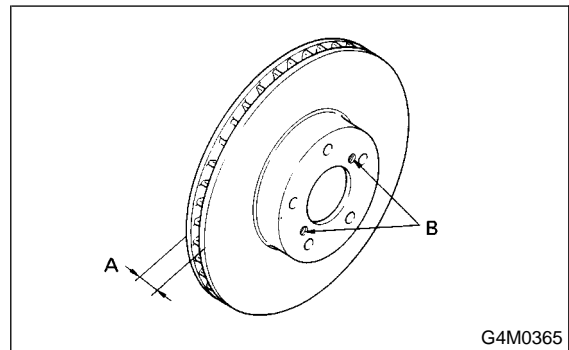

#### NOTE:

Make sure that micrometer is set 5 mm (0.20 in) inward of rotor outer perimeter.

	Standard value	Service limit	Disc outer dia.
Disc rotor thickness A	24.0 mm (0.945 in)	22.0 mm (0.866 in)	277 mm (10.91 in)

## 4. Front Disc Brake Assembly

S405176

### A: REMOVAL S405176A18

- 1) Loosen wheel nuts, jack-up vehicle, support it with safety stands, and remove wheel.
- 2) Remove union bolt and disconnect brake hose from caliper body assembly.

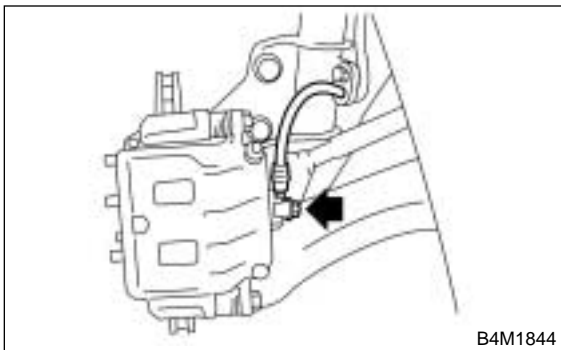

- 3) Remove bolt securing lock pin to caliper body.

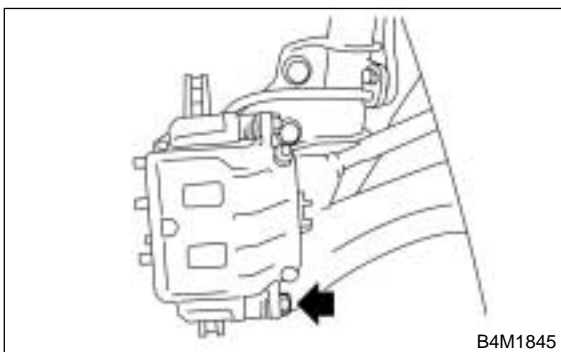

- 4) Raise caliper body and move it toward vehicle center to separate it from support.
- 5) Remove support from housing.

**NOTE:**

Remove support only when replacing it or the rotor. It need not be removed when servicing caliper body assembly.

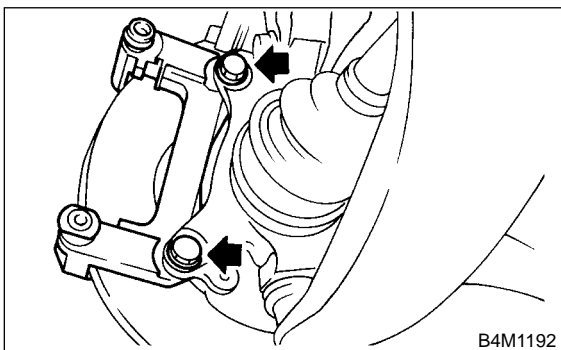

- 6) Remove disc rotor from hub.

**NOTE:**

If disc rotor seizes up within hub, drive disc rotor out by installing an 8-mm bolt in holes B on the rotor.

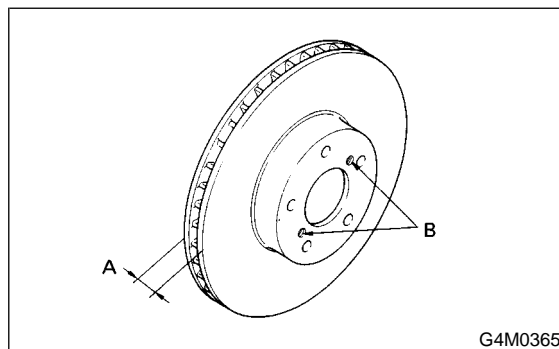

- 7) Clean mud and foreign particles from caliper body assembly and support.



# FRONT DISC BRAKE ASSEMBLY

Brake

## B: INSTALLATION S405176A11

- 1) Install disc rotor on hub.
- 2) Install support on housing.

### **Tightening torque:**

**78 N·m (8 kgf·m, 58 ft·lb)**

### **CAUTION:**

● Always replace the pads for both the left and right wheels at the same time. Also replace pad clips if they are twisted or worn.

● A wear indicator is provided on the inner disc brake pad. If the pad wears down to such an extent that the end of the wear indicator contacts the disc rotor, a squeaking sound is produced as the wheel rotates. If this sound is heard, replace the pad.

● When replacing the pads, replace pads of the right and left wheels at the same time.

3) Apply thin coat of Molykote AS880N (Part No. 26298AC000) to the frictional portion between pad and pad clip.

4) Apply thin coat of Molykote AS880N (Part No. 26298AC000) to the frictional portion between pad and inner shim. (Australia model)

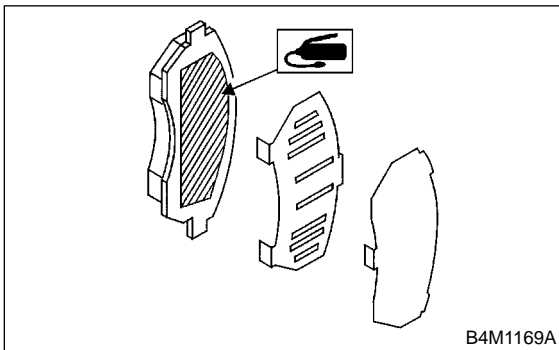

- 5) Install pads on support.
- 6) Install caliper body on support.

### **Tightening torque:**

**39 N·m (4.0 kgf·m, 28.9 ft·lb)**

- 7) Connect brake hose.

### **Tightening torque:**

**18 N·m (1.8 kgf·m, 13.0 ft·lb)**

### **CAUTION:**

**Replace brake hose gaskets with new ones.**

- 8) Bleed air from brake system.  
<Ref. to BR-47, Air Bleeding.>

## C: DISASSEMBLY S405176A06

- 1) Clean mud and foreign particles from caliper body assembly and support.

### **CAUTION:**

**Be careful not to allow foreign particles to enter inlet (at brake hose connector).**

- 2) Using a standard screwdriver, remove boot ring from piston.

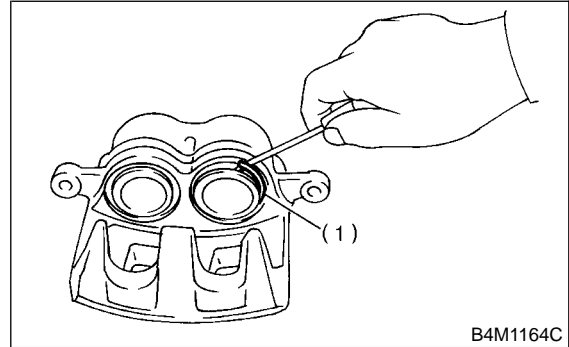

- (1) Boot ring

- 3) Remove boot from piston end.
- 4) Gradually supply compressed air via caliper body brake hose to force piston out.

### **CAUTION:**

**Place a wooden block as shown in Figure to prevent damage to piston.**

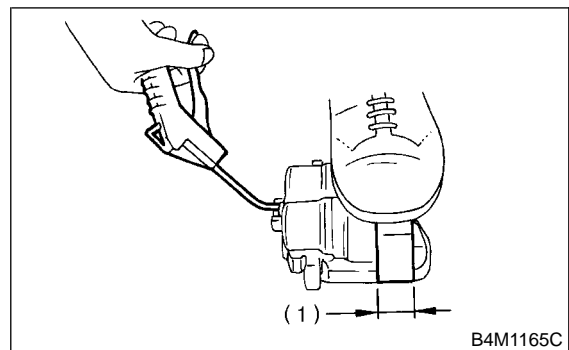

- (1) Place a 30 mm (1.18 in) wide wooden block here.

- 5) Remove piston seal from caliper body cylinder.

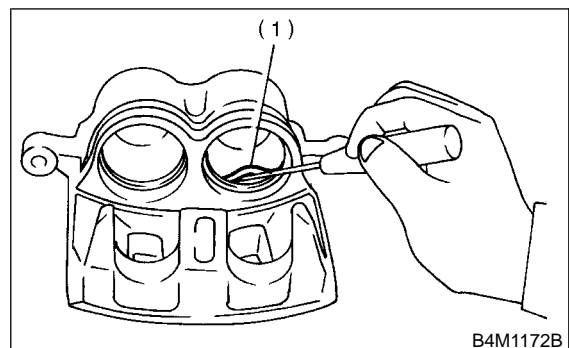

- (1) Piston pin

6) Remove lock pin boot and guide pin boot.

## D: ASSEMBLY S405176A02

- 1) Clean caliper body interior using brake fluid.
- 2) Apply a coat of brake fluid to piston seal and fit piston seal in groove on caliper body.
- 3) Apply a coat of brake fluid to the entire inner surface of cylinder and outer surface of piston.
- 4) Insert piston into cylinder.

### CAUTION:

**Do not force piston into cylinder.**

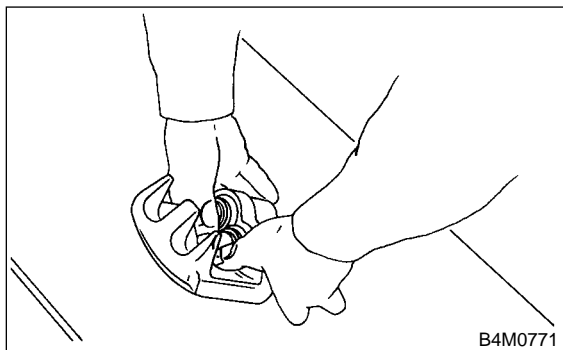

5) Apply a coat of specified grease to boot and fit in groove on ends of cylinder and piston.

### Grease:

**NIGLUBE RX-2 (Part No. 003606000)**

To facilitate installation, fit boot starting with piston end.

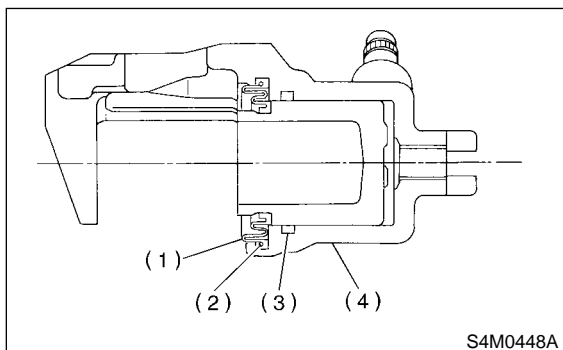

- (1) Piston boot
- (2) Boot ring
- (3) Piston seal
- (4) Caliper body

- 6) Position boot in grooves on cylinder and piston.
- 7) Install boot ring. Be careful not scratch boot.

8) Apply a coat of specified grease to lock pin and guide pin, outer surface, cylinder inner surface, and boot grooves.

### Grease:

**NIGLUBE RX-2 (Part No. 003606000)**

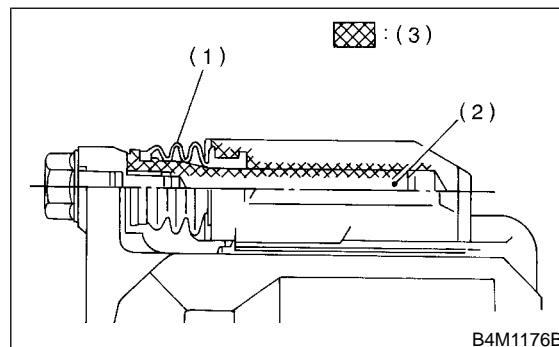

- (1) Pin boot
- (2) Lock pin or guide pin
- (3) Apply grease.

9) Install lock pin boot and guide pin boot on support.

## E: INSPECTION S405176A10

### NOTE:

Repair or replace faulty parts.

- 1) Check caliper body and piston for uneven wear, damage or rust.
- 2) Check rubber parts for damage or deterioration.

# REAR BRAKE PAD

Brake

## 5. Rear Brake Pad S405175

### A: REMOVAL S405175A18

- 1) Loosen wheel nuts, jack-up vehicle, support it with safety stands, and remove wheel.
- 2) Remove lock pin.

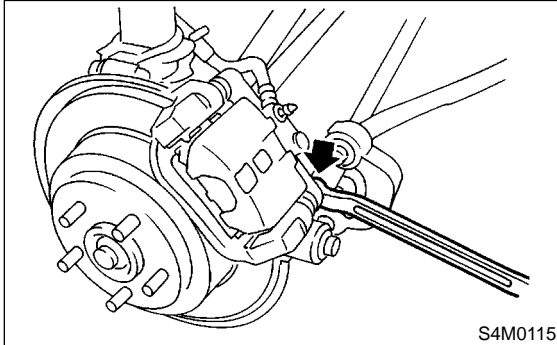

- 3) Raise caliper body.
- 4) Remove pad from support.

#### NOTE:

If brake pad is difficult to remove, use the same procedure as for front disc brake pad.

<Ref. to BR-20 REMOVAL, Front Brake Pad.>

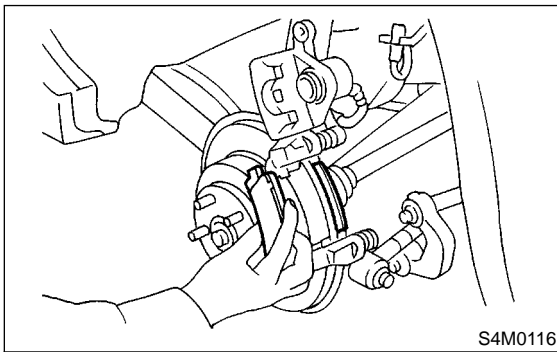

### B: INSTALLATION S405175A11

- 1) Apply thin coat of Molykote AS880N (Part No. 26298AC000) to the frictional portion between pad and pad clip.
- 2) Install pad on support.
- 3) Install caliper body on support.

#### Tightening torque:

**39 N·m (4.0 kgf·m, 28.9 ft·lb)**

#### NOTE:

If it is difficult to push piston during pad replacement, loosen air bleeder to facilitate work.

### C: INSPECTION S405175A10

Check pad thickness (including back metal).

#### Pad thickness: A

**Standard value**

**14.0 mm (0.551 in)**

**Wear limit**

**6.5 mm (0.256 in)**

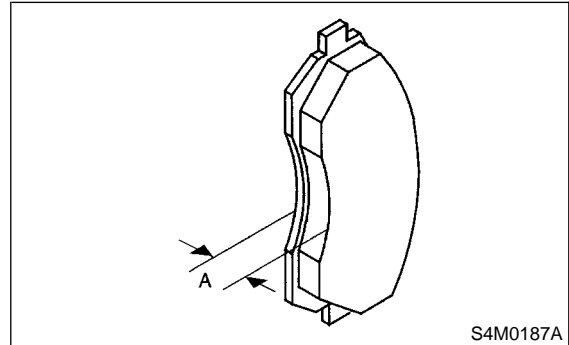

#### CAUTION:

- Always replace the pads for both the left and right wheels at the same time. Also replace pad clips if they are twisted or worn.
- A wear indicator is provided on the inner disc brake pad. If the pad wears down to such an extent that the end of the wear indicator contacts the disc rotor, a squeaking sound is produced as the wheel rotates. If this sound is heard, replace the pad.
- Replace pad if there is oil or grease on it.

## 6. Rear Disc Rotor S405177

### A: REMOVAL S405177A18

- 1) Disconnect battery ground terminal from battery.
- 2) Loosen wheel nuts, jack-up vehicle, support it with safety stands, and remove wheel.
- 3) Remove the two mounting bolts and remove the disc brake assembly.

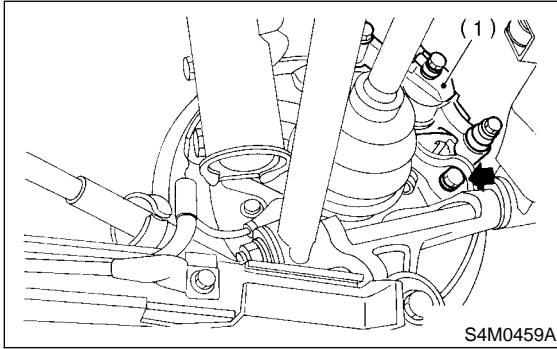

(1) Disc brake

- 4) Suspend the disc brake assembly so that the hose is not stretched.
- 5) Pull down and release parking brake.
- 6) Remove the disc rotor.

#### NOTE:

If the disc rotor is difficult to remove try the following two methods in order.

- (1) Turn adjusting screw using a slot-type screwdriver until brake shoe gets away enough from the disc rotor.

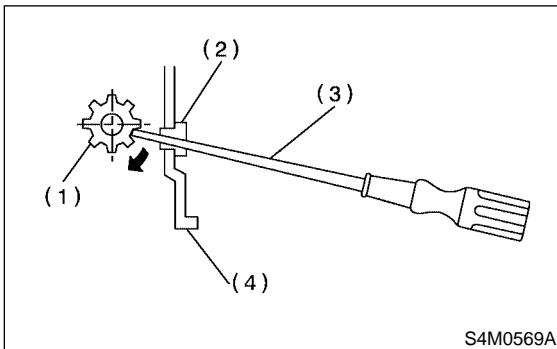

- (1) Adjusting screw
- (2) Cover
- (3) Slot-type screwdriver
- (4) Back plate

- (2) If disc rotor seizes up within hub, drive disc rotor out by installing an 8-mm bolt in holes B on the rotor.

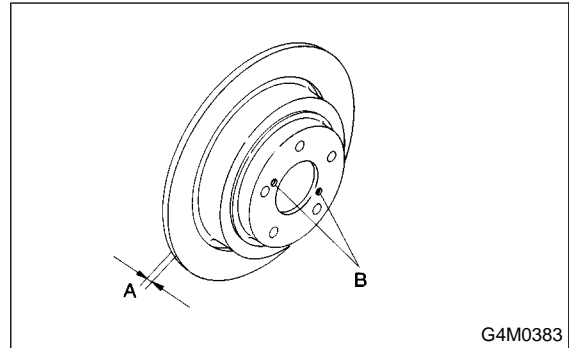

G4M0383

### B: INSTALLATION S405177A11

- 1) Install in the reverse order of removal.
- 2) Adjust parking brake. <Ref. to PB-11 ADJUSTMENT, Parking Brake Assembly (Rear Disc Brake).>

# REAR DISC ROTOR

Brake

## C: INSPECTION S405177A10

- 1) Secure disc rotor by tightening the five wheel nuts.
- 2) Set a dial gauge on the disc rotor. Turn disc rotor to check runout.

### CAUTION:

**Securely adjust disc rotor to hub.**

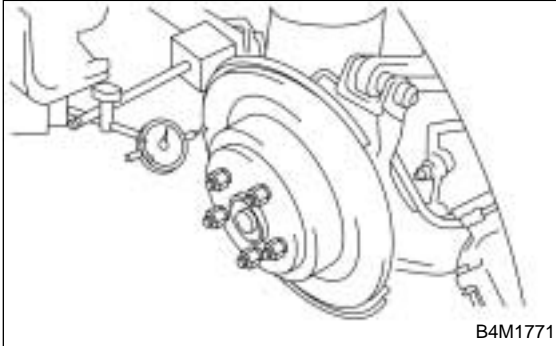

### NOTE:

- Make sure that dial gauge is set 5 mm (0.20 in) inward of rotor outer perimeter.
- If disc rotor runout is above standard value, inspect play of hub bearing axial direction and runout of axle hub. <Ref. to DS-31, INSPECTION, Rear Axle.>

**Disc rotor runout limit:**  
**0.070 mm (0.0028 in)**

- 3) Measure disc rotor thickness.  
If thickness of disc rotor is outside the standard value, replace disc rotor.

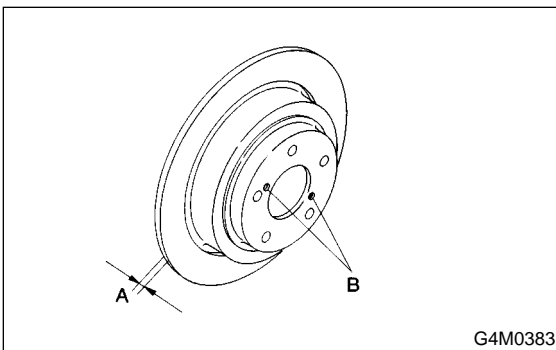

### NOTE:

Make sure that micrometer is set 5 mm (0.20 in) inward of rotor outer perimeter.

**Disc rotor thickness: A**  
**Standard value**  
**10 mm (0.39 in)**  
**Service limit**  
**8.5 mm (0.335 in)**

## 7. Rear Disc Brake Assembly

S405172

### A: REMOVAL S405172A18

- 1) Loosen wheel nuts, jack-up vehicle, support it with safety stands, and remove wheel.
- 2) Disconnect brake hose from caliper body assembly.

#### CAUTION:

**Do not allow brake fluid to come in contact with vehicle body; wipe off completely if spilled.**

- 3) Remove lock pin.

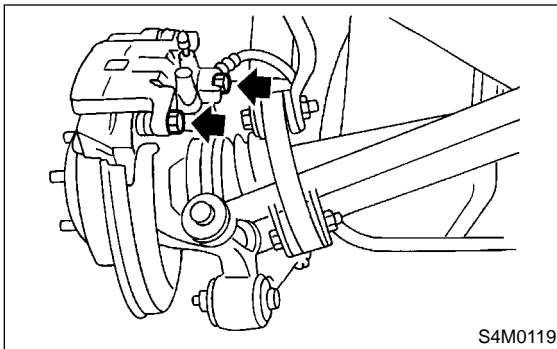

- 4) Raise caliper body and move it toward vehicle center to separate it from support.
- 5) Remove support from back plate.

#### NOTE:

Remove support only when replacing it or the rotor. It need not be removed when servicing caliper body assembly.

- 6) Clean mud and foreign particles from caliper body assembly and support.

#### CAUTION:

**Be careful not to allow foreign particles to enter inlet (at brake hose connector).**

### B: INSTALLATION S405172A11

- 1) Install disc rotor on hub.
- 2) Install support on back plate.

#### Tightening torque:

**78 N·m (8.0 kgf-m, 58 ft-lb)**

#### CAUTION:

- Always replace the pads for both the left and right wheels at the same time. Also replace pad clips if they are twisted or worn.

- A wear indicator is provided on the inner disc brake pad. If the pad wears down to such an extent that the end of the wear indicator contacts the disc rotor, a squeaking sound is produced as the wheel rotates. If this sound is heard, replace the pad.

- Replace pads if there is oil or grease on them.

- 3) Apply thin coat of Molykote AS880N (Part No. 26298AC000) to the frictional portion between pad and pad clip.
- 4) Install pads on support.
- 5) Install caliper body on support.

#### Tightening torque:

**39 N·m (4.0 kgf-m, 28.9 ft-lb)**

- 6) Connect brake hose.

#### Tightening torque:

**18 N·m (1.8 kgf-m, 13.0 ft-lb)**

#### CAUTION:

- The brake hose must be connected without any twist.
- Replace brake hose gaskets with new ones.

- 7) Bleed air from brake system.  
<Ref. to BR-47, Air Bleeding.>

# REAR DISC BRAKE ASSEMBLY

Brake

## C: DISASSEMBLY S405172A06

1) Remove the boot ring.

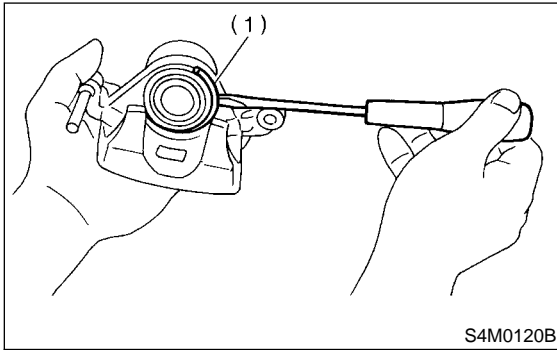

(1) Boot ring

2) Remove the piston boot.

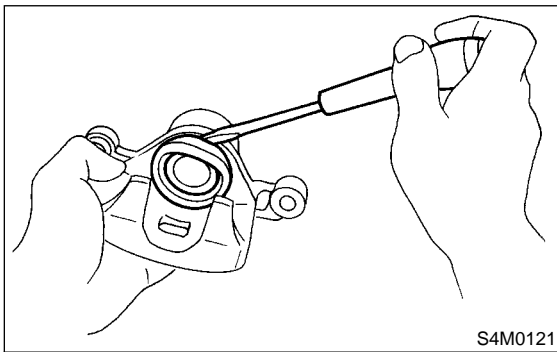

S4M0121

3) Gradually supply compressed air via inlet of caliper body to force piston out.

### CAUTION:

- Place a wooden block as shown in Figure to prevent damage to piston.
- Do not apply excessively high-pressure.

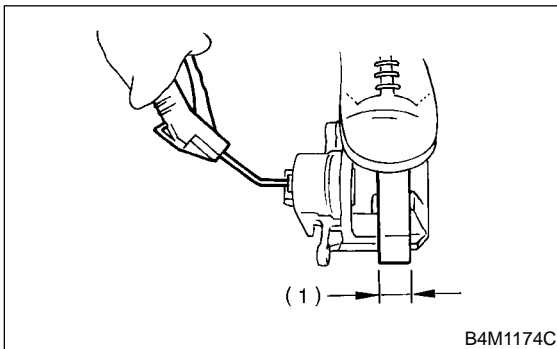

B4M1174C

(1) Place a 30 mm (1.18 in) wide wooden block here.

4) Remove piston seal from caliper body cylinder.

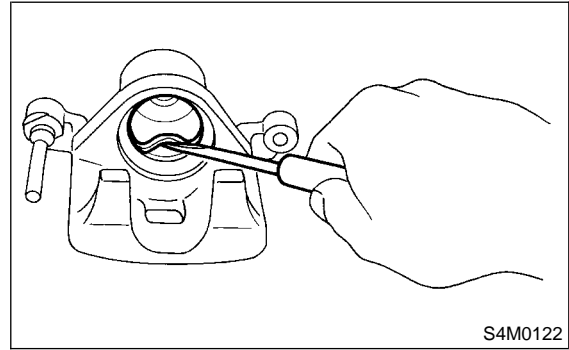

S4M0122

5) Remove lock pin sleeve and boot from caliper body.

6) Remove guide pin boot.

## D: ASSEMBLY S405172A02

- 1) Clean caliper body interior using brake fluid.
- 2) Apply a coat of brake fluid to piston seal and fit piston seal in groove on caliper body.
- 3) Apply a coat of brake fluid to the entire inner surface of cylinder and outer surface of piston.
- 4) Insert piston into cylinder.

### CAUTION:

**Do not force piston into cylinder.**

- 5) Apply a coat of specified grease to boot and fit in groove on ends of cylinder and piston.

### Grease:

**NIGLUBE RX-2 (Part No. 003606000)**

- 6) Install the piston boot to the caliper body, and attach boot ring.

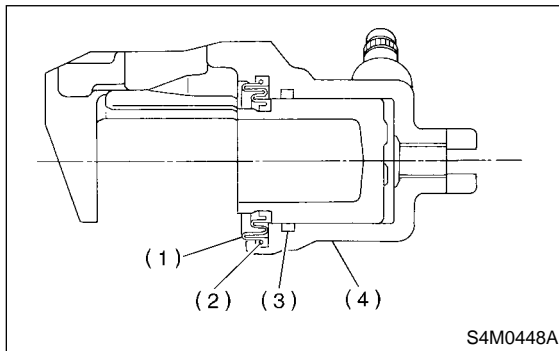

- (1) Piston boot
- (2) Boot ring
- (3) Piston seal
- (4) Caliper body

- 7) Apply a coat of specified grease to guide pin, outer surface, sleeve outer surface, cylinder inner surface, and boot grooves.

### Grease:

**NIGLUBE RX-2 (Part No. 003606000)**

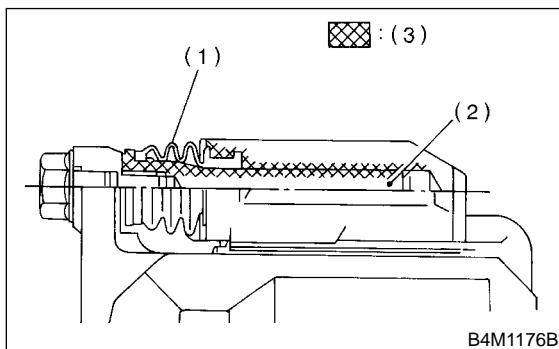

- (1) Pin boot
- (2) Lock pin or guide pin
- (3) Apply grease.

- 8) Install guide pin boot on caliper body.
- 9) Install lock pin boot on caliper body and insert lock pin sleeve into place.

## E: INSPECTION S405172A10

### NOTE:

Repair or replace faulty parts.

- 1) Check caliper body and piston for uneven wear, damage or rust.
- 2) Check rubber parts for damage or deterioration.



# REAR DRUM BRAKE SHOE

Brake

## 8. Rear Drum Brake Shoe S405174

### A: REMOVAL S405174A18

- 1) Loosen wheel nuts, jack-up vehicle, support it with safety stands, and remove wheel.
- 2) Release parking brake.
- 3) Remove brake drum from brake assembly.

#### NOTE:

- If it is difficult to remove brake drum, remove adjusting hole cover from drum, and then turn adjuster assembly pawls using a slot-type screwdriver until brake shoe separates from the drum.

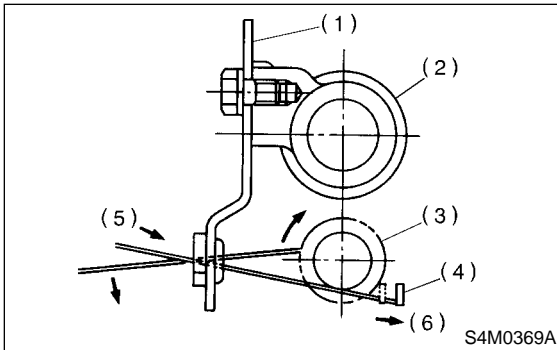

- (1) Back plate
- (2) Wheel cylinder
- (3) Adjuster ASSY pawls
- (4) Adjusting lever
- (5) Tightening direction
- (6) Push.

- If brake drum is difficult to remove, drive it out by installing an 8-mm bolt into bolt hole in brake drum.

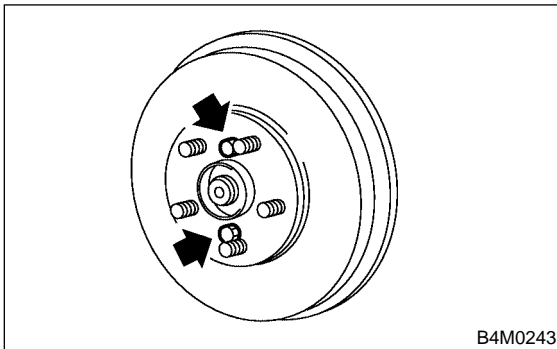

- 4) Hold hold-down pin by securing rear of back plate with your hand.

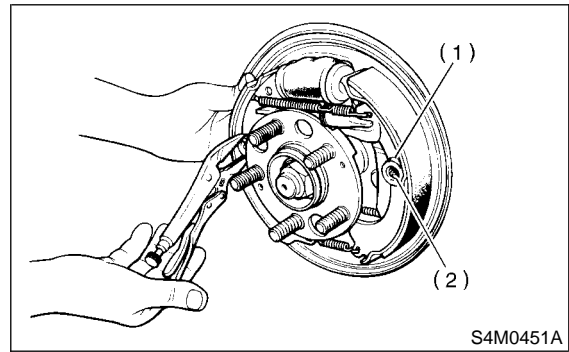

- (1) Hold-down cup
- (2) Hold-down pin

- 5) Disconnect hold-down cup from hold-down pin by rotating hold-down cup.
- 6) Disconnect lower shoe return spring from shoes.

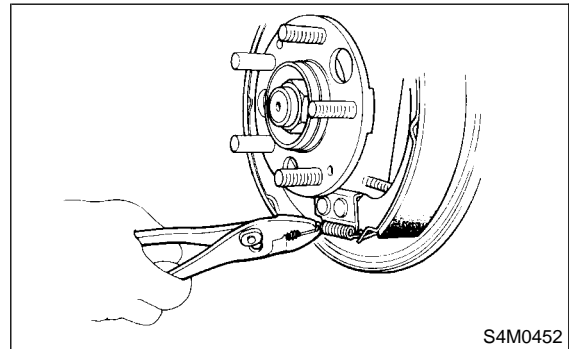

- 7) Remove shoes one by one from back plate with adjuster.

#### CAUTION:

Be careful not to bend parking brake cable excessively when removing brake shoes.

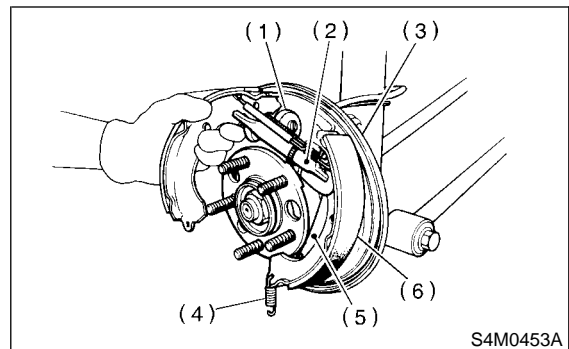

- (1) Wheel cylinder
- (2) Adjuster
- (3) Back plate
- (4) Lower shoe return spring
- (5) Parking lever
- (6) Trailing shoe

8) Disconnect parking brake cable from parking lever.

6) While positioning shoes (one at a time) in groove on wheel cylinder, secure shoes.

## B: INSTALLATION S405174A11

- 1) Clean back plate and wheel cylinder.
- 2) Apply grease to portions indicated by arrows in Figure.

### Brake grease:

**Dow Corning Molykote No. 7439 (Part No. 725191460)**

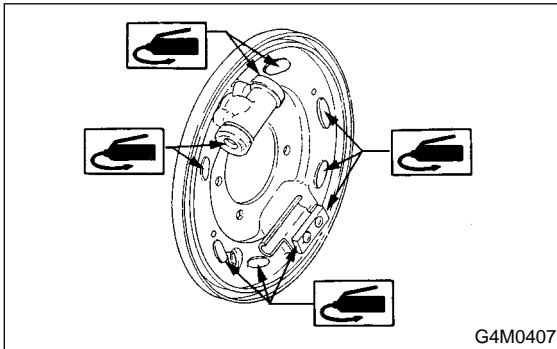

3) Apply grease to adjusting screw and both ends of adjuster.

### Brake grease:

**Dow Corning Molykote No. 7439 (Part No. 725191460)**

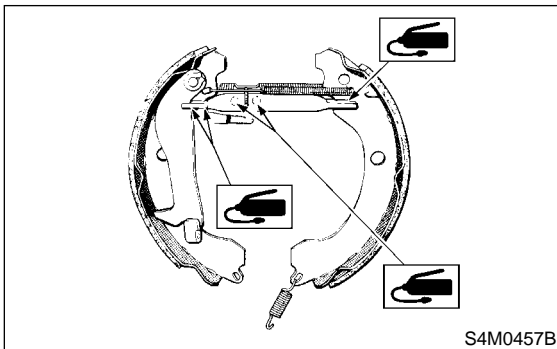

- 4) Connect upper shoe return spring to shoes.
- 5) Connect parking brake cable to parking lever.

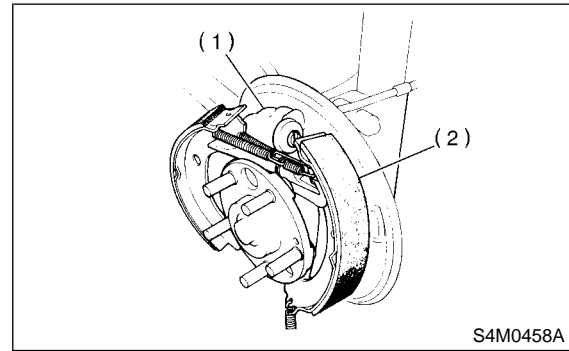

- (1) Wheel cylinder
- (2) Shoe (Trailing)

- 7) Fix shoes by connecting hold-down cup to hold-down pin.
- 8) Connect lower shoe return spring.
- 9) Set the outside diameter of brake shoes less than 0.5 to 0.8 mm (0.020 to 0.031 in) in comparison with the inside diameter of brake drum.
- 10) Install drum.

## C: INSPECTION S405174A10

- 1) Measure the lining thickness.

### Lining thickness:

**Standard 4.1 mm (0.161 in)**

**Service limit 1.5 mm (0.059 in)**

- 2) If the deformation or wear of back plate, shoe, etc. are notable, replace them.
- 3) When the shoe return spring tension is excessively weakened, replace it, taking care to identify upper and lower springs.

## 9. Rear Drum Brake Drum S405180

### A: REMOVAL S405180A18

- 1) Loosen wheel nuts, jack-up vehicle, support it with safety stands, and remove wheel.
- 2) Release parking brake.
- 3) Remove brake drum from brake assembly.

**NOTE:**

- If it is difficult to remove brake drum, remove adjusting hole cover from drum, and then turn adjuster assembly pawls using a slot-type screwdriver until brake shoe separates from the drum.

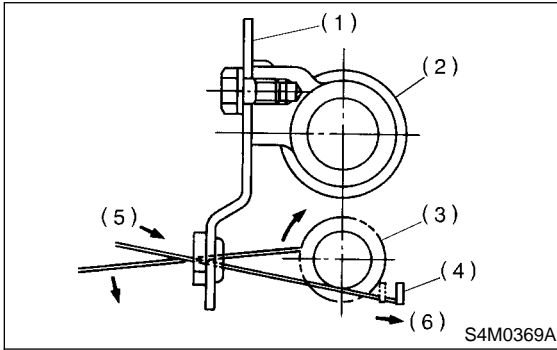

- (1) Back plate
- (2) Wheel cylinder
- (3) Adjuster ASSY pawls
- (4) Adjusting lever
- (5) Tightening direction
- (6) Push.

- If brake drum is difficult to remove, drive it out by installing an 8-mm bolt into bolt hole in brake drum.

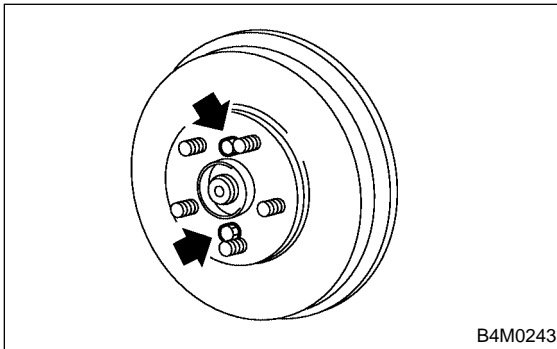

### B: INSTALLATION S405180A11

- 1) Set the outside diameter of brake shoes less than 0.5 to 0.8 mm (0.020 to 0.031 in) in comparison with the inside diameter of brake drum.
- 2) Install drum.

### C: INSPECTION S405180A10

- 1) If the inside surface of brake drum is streaked, correct the surface. And, if it is unevenly worn, taperingly streaked, or the outside surface of brake drum is damaged, correct or replace it.
- 2) Measure the drum inner diameter.

**Drum inner diameter: "L"**

**Standard 228.6 mm (9 in)**

**Service limit 230.6 mm (9.08 in)**

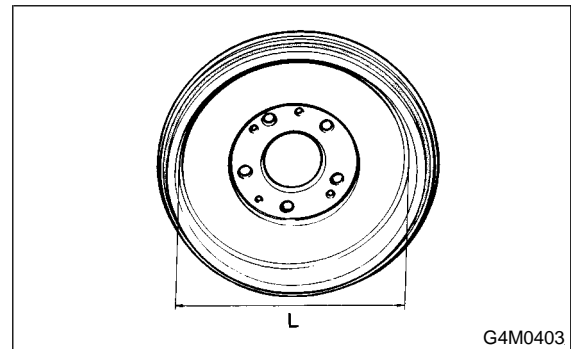

## 10. Rear Drum Brake Assembly

S405179

### A: REMOVAL S405179A18

- 1) Disconnect battery ground terminal from battery.
- 2) Loosen wheel nuts, jack-up vehicle, support it with safety stands, and remove wheel.
- 3) Release parking brake.
- 4) Remove brake drum from brake assembly. <Ref. to BR-34, REMOVAL, Rear Drum Brake Drum.>
- 5) Remove brake shoe. <Ref. to BR-32, REMOVAL, Rear Drum Brake Shoe.>
- 6) Unscrew the brake pipe flare nut and disconnect brake pipe.

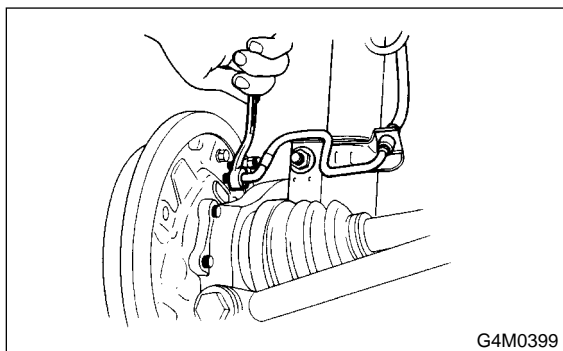

- 7) Disconnect ABS sensor from back plate. (only vehicle equipped with ABS)
- 8) Remove hub. <Ref. to DS-23, Rear Axle.>
- 9) Remove the bolts installing back plate, and then, remove brake assembly.

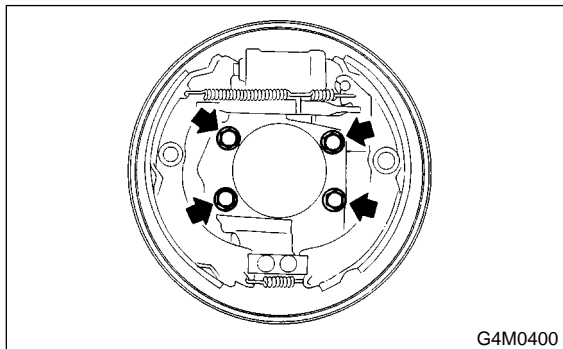

- 10) Remove the bolts installing wheel cylinder on back plate, and remove it.

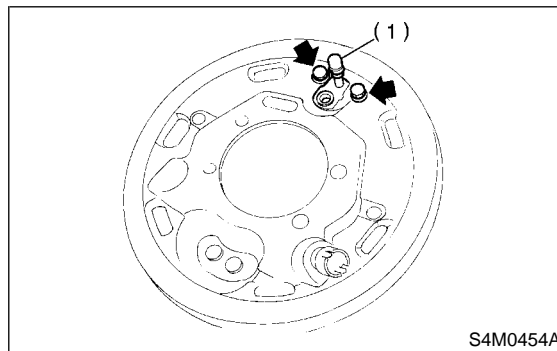

(1) Air bleeder

### B: INSTALLATION S405179A11

- 1) Clean back plate and wheel cylinder.
- 2) Install wheel cylinder on back plate, and tighten bolts.

**Tightening torque:**

**10 N·m (1.0 kgf·m, 7.2 ft·lb)**

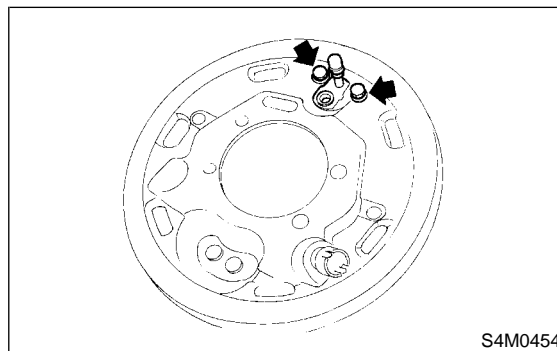

- 3) Apply grease to portions indicated by arrows in Figure.

**Brake grease:**

**Dow Corning Molykote No. 7439 (Part No. 725191460)**

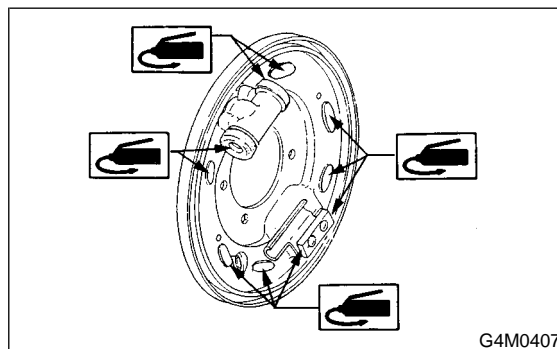

# REAR DRUM BRAKE ASSEMBLY

Brake

4) Install brake assembly on housing, and tighten bolts to install back plate.

**Tightening torque:**

**52 N·m (5.3 kgf-m, 38.3 ft-lb)**

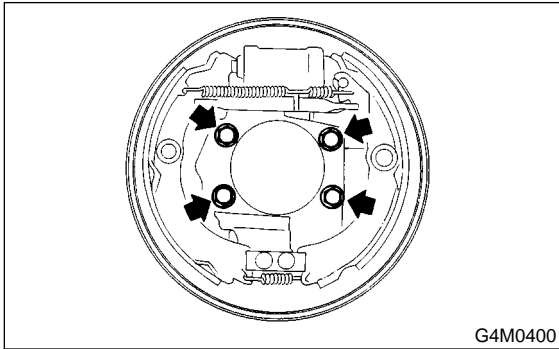

5) Install hub. <Ref. to DS-23, Rear Axle.>  
6) Connect brake pipe, and tighten brake pipe flange nut.

**Tightening torque:**

**15 N·m (1.5 kgf-m, 10.8 ft-lb)**

7) Connect ABS sensor to back plate. (only vehicle equipped with ABS)

**Tightening torque:**

**32 N·m (3.3 kgf-m, 24 ft-lb)**

8) Apply grease to adjusting screw and both ends of adjuster.

**Brake grease:**

**Dow Corning Molykote No. 7439 (Part No. 725191460)**

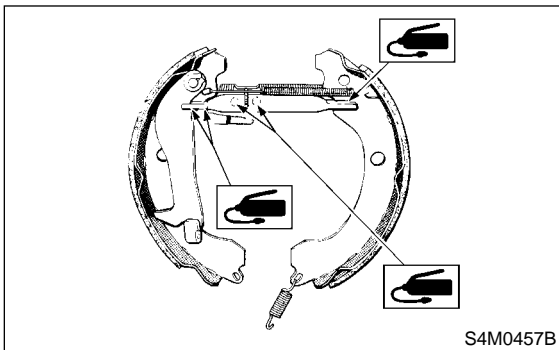

9) Install brake shoe. <Ref. to BR-33, INSTALLATION, Rear Drum Brake Shoe.>  
10) Install drum. <Ref. to BR-34, INSTALLATION, Rear Drum Brake Drum.>  
11) Bleed air from brake system. <Ref. to BR-47, Air Bleeding.>

## C: DISASSEMBLY

S405179A06

1) Remove right and left dust boots from wheel cylinder.

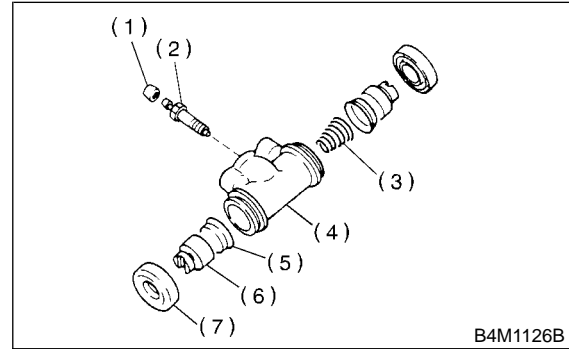

- (1) Bleeder cap
- (2) Bleeder screw
- (3) Spring
- (4) Cylinder
- (5) Cup
- (6) Piston
- (7) Boot

2) Remove piston, cup, spring and air bleeder screw and cap.

## D: ASSEMBLY

S405179A02

1) Clean all parts in brake fluid. Check and replace faulty parts.

- Cup and boot for damage or fatigue
- Cylinder, piston and spring or damage or rust formation

2) Assembly is the reverse order of disassembly.  
(1) When installing the cup, use ST, apply brake fluid to the frictional surface for smooth installation and pay attention to cup direction.  
(2) STs are available in different sizes.

**CAUTION:**

- When replacing the repair kit, make sure that the sizes of cylinder and cup are the same as those which were replaced.
- Use only the tool of the correct size.

ST. ADAPTER	
Applicable size	Part No.
19.0 mm (3/4 in)	926460000

**CAUTION:**

While assembling, be careful to prevent any metal chip, dust or dirt from entering the wheel cylinder.

**E: INSPECTION**

S405179A10

- 1) Check wheel cylinder for leakage.
- 2) Inspect the disassembled parts for wear, rust or damage.
- 3) Inspect lining thickness. <Ref. to BR-33, INSPECTION, Rear Drum Brake Shoe.>
- 4) Inspect brake drum. <Ref. to BR-34, INSPECTION, Rear Drum Brake Drum.>

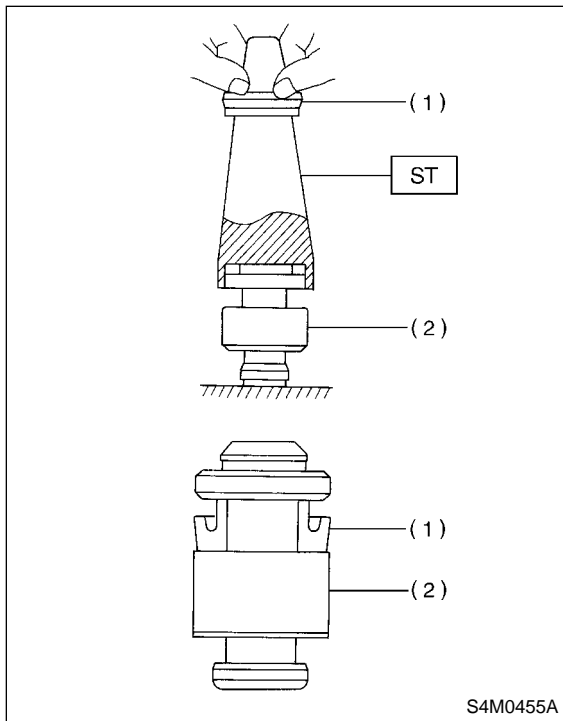

- (1) Cup
- (2) Piston

3) Apply rubber grease to the boot inside as shown in Figure.

**CAUTION:**

Never use brake grease.

**Grease:**

**NIGLUBE RX-2 (Part No. 003606000)**

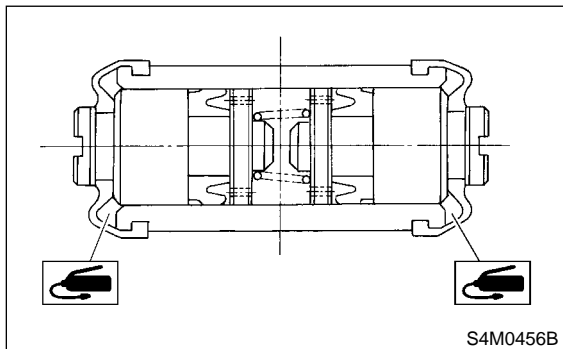

## 11. Master Cylinder S405168

### A: REMOVAL S405168A18

- 1) Pull up parking brake lever, and block the tires.
- 2) Disconnect battery ground terminal from battery.
- 3) Thoroughly drain brake fluid from reservoir tank.
- 4) Disconnect fluid level indicator harness connector.
- 5) Remove brake pipes from master cylinder.
- 6) Remove master cylinder mounting nuts, and take out master cylinder from brake booster.

#### CAUTION:

Be extremely careful not to spill brake fluid. Brake fluid spilt on the vehicle body will harm the painted surface; wipe it off quickly if spilt.

### B: INSTALLATION S405168A11

- 1) Install in the reverse order of removal.

#### Tightening torque:

- Master cylinder mounting nut**  
14 N·m (1.4 kgf-m, 10.1 ft-lb)
- Piping flare nut**  
15 N·m (1.5 kgf-m, 10.8 ft-lb)

#### CAUTION:

Be sure to use recommended brake fluid.

- 2) Bleed air from brake system. <Ref. to BR-47, Air Bleeding.>

### C: DISASSEMBLY S405168A06

#### 1. PRECAUTIONS FOR DISASSEMBLING

S405168A0602

- 1) Remove mud and dirt from the surface of brake master cylinder.
- 2) Prepare tools necessary for disassembly operation, and arrange them neatly on work bench.
- 3) Clean work bench.

### 2. DISASSEMBLING PROCEDURE S405168A0603

- 1) Remove pin with drift pin which secures reserve tank to master cylinder.
- 2) Remove cylinder pin with magnetic pick-up tool while pushing in primary piston. (Only vehicle equipped with ABS)

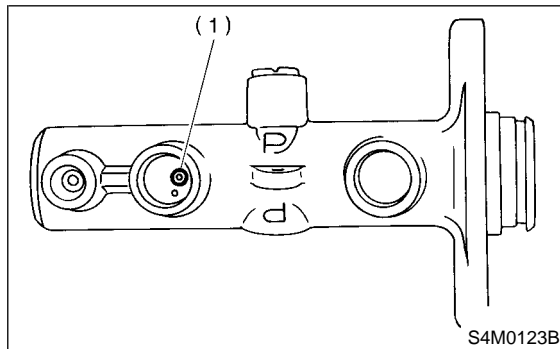

(1) Cylinder pin

- 3) Pry up the pawl and remove the piston retainer.

#### NOTE:

Piston may jump out from master cylinder.

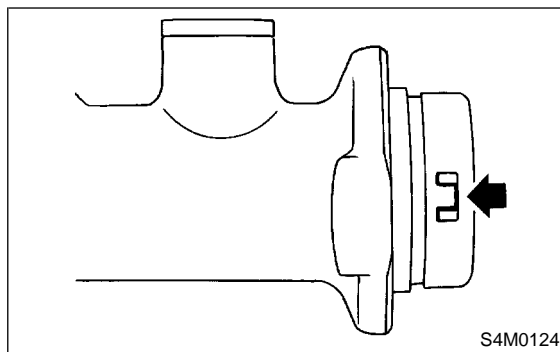

- 4) Extract primary piston assembly and secondary piston assembly.

#### CAUTION:

- Do not disassemble the piston assembly; otherwise, the spring set value may be changed.
- Use brake fluid or methanol to wash inside wall of cylinder, pistons and piston cups. Be careful not to damage parts when washing. If methanol is used for washing, do not dip rubber parts, such as piston cups, in it for more than 30 seconds; otherwise, they may become swelled.

## D: ASSEMBLY S405168A02

### 1. PRECAUTIONS FOR ASSEMBLING

S405168A0201

- 1) When assembling, be sure to use recommended brake fluid.
- 2) Ensure that the inside wall of cylinder, pistons, and piston cups are free from dirt when assembling.
- 3) Be extremely careful not to damage, scratch, or dent cylinder inside wall, pistons, and piston cups.
- 4) Do not drop parts. Never attempt to use any part that has been dropped accidentally.

### 2. ASSEMBLING PROCEDURE S405168A0202

- 1) Assembling piston assembly:  
Apply recommended brake fluid to inside wall of cylinder, and to outer surface of piston assembly, and install piston assemblies carefully into cylinder.
- 2) Press the pawl (only vehicle equipped with ABS) and install the piston retainer into the master cylinder.

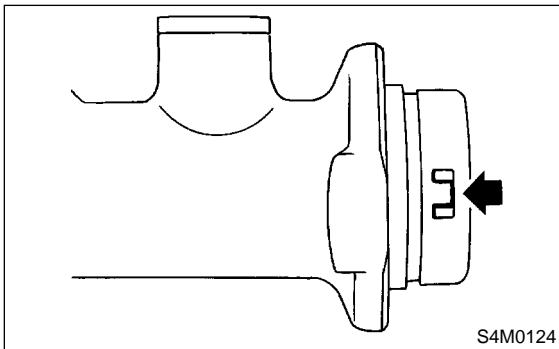

- 3) Install seal to reservoir tank.

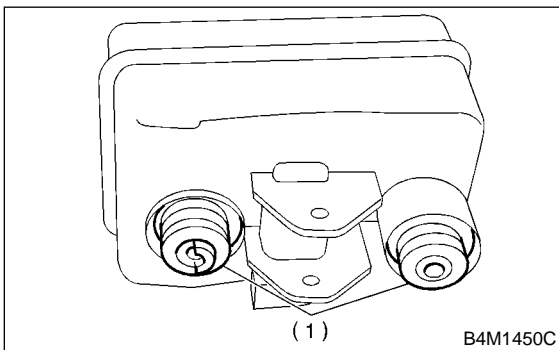

(1) Seal

- 4) Install pin with drift pins which secures reservoir tank to master cylinder.

## E: INSPECTION S405168A10

If any damage, deformation, wear, swelling, rust, and other faults are found on the primary piston assembly, secondary piston assembly, supply valve stopper, or gasket, replace the faulty part.

### CAUTION:

- The primary and secondary pistons must be replaced as complete assemblies.
- The service limit of the clearance between each piston and the master cylinder inner dia. is 0.11 mm (0.0043 in).
- When handling parts, be extremely careful not to damage or scratch the parts, or let any foreign matter get on them.



## 12. Brake Booster S405166

### A: REMOVAL S405166A18

#### CAUTION:

If external force "F" is applied from above when brake booster is placed in this position, the resin portion as indicated by "P", may be damaged.

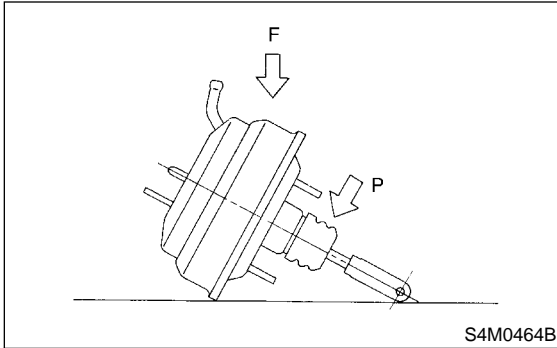

- 1) Pull up parking brake lever, and block the tires.
- 2) Disconnect battery ground terminal from battery.
- 3) Remove or disconnect the following parts at engine compartment.
  - (1) Disconnect connector for brake fluid level indicator.
  - (2) Remove brake pipes from master cylinder.
  - (3) Remove master cylinder installing nuts.
  - (4) Disconnect vacuum hose from brake booster.
- 4) Remove the following parts from the pedal bracket.
  - (1) Snap pin and clevis pin
  - (2) Four brake booster installing nuts
- 5) Remove brake booster while shunning brake pipes.

#### NOTE:

- Be careful not to drop brake booster. Brake booster should be discarded if it has been dropped.
- Use special care when handling operating rod. If excessive force is applied to operating rod, sufficient to cause a change in the angle in excess of  $\pm 3^\circ$ , it may result in damage to the power piston cylinder.
- Use care when placing brake booster on the floor.

- Do not change the push rod length. If it has been changed, reset the projected length "L" to the standard length.

#### Standard:

$$L = 10 \text{ mm (0.39 in)}$$

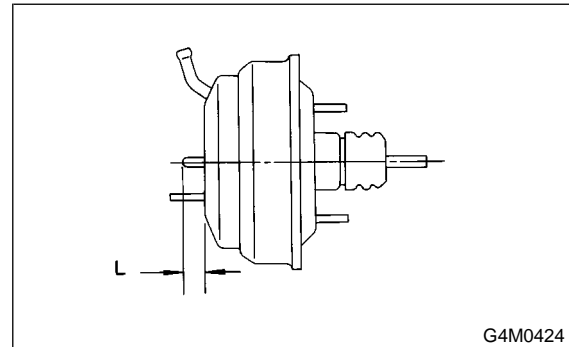

## B: INSTALLATION S405166A11

- 1) Mount brake booster in position.
- 2) Connect operating rod to brake pedal with clevis pin and snap pin.

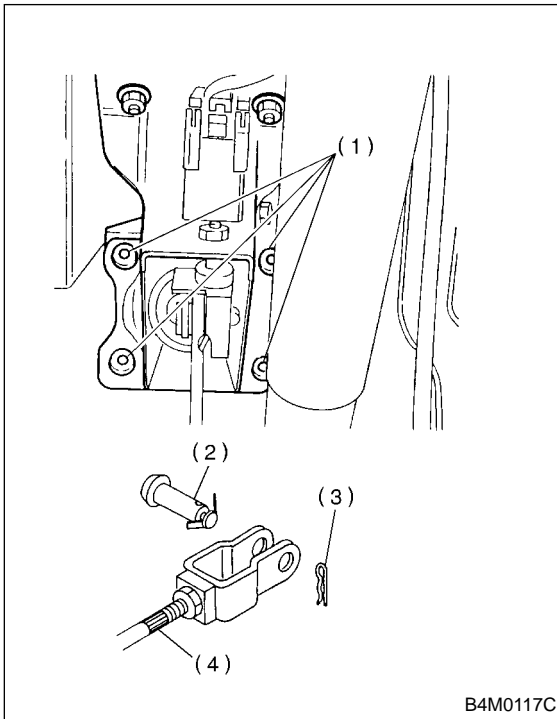

- (1) Nuts
- (2) Clevis pin
- (3) Snap pin
- (4) Operating rod

- 3) Connect vacuum hose to brake booster.

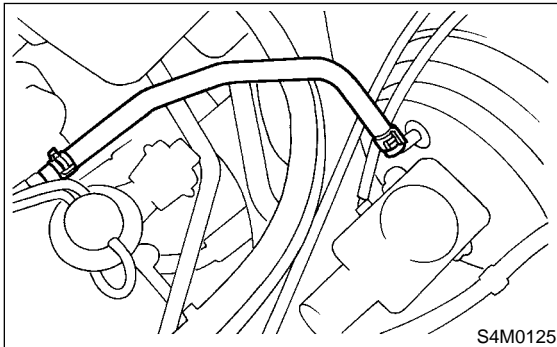

- 4) Mount master cylinder onto brake booster.
- 5) Connect brake pipes to master cylinder.
- 6) Connect electric connector for brake fluid level indicator.

- 7) Adjust operating rod of brake booster.

**Standard: L**

**LHD:**

**144.6 mm (5.69 in)**

**RHD:**

**173.2 mm (6.82 in)**

If it is not in specified value, adjust it by adjusting brake booster operating rod.

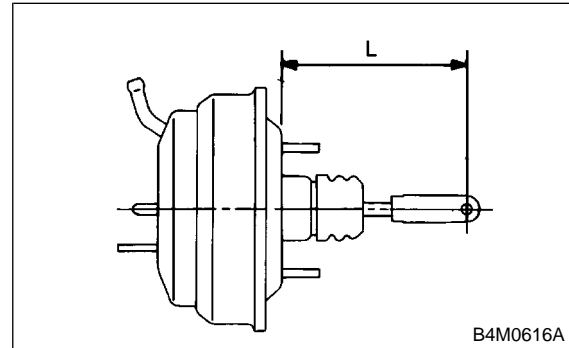

- 8) Measure the clearance between threaded end of stop light switch and stopper. If it is not in specified value, adjust it by adjusting position of stop light switch.

**CAUTION:**

**Be careful not to rotate stop light switch.**

**Stop light switch clearance: A**

**0.3 mm (0.012 in)**

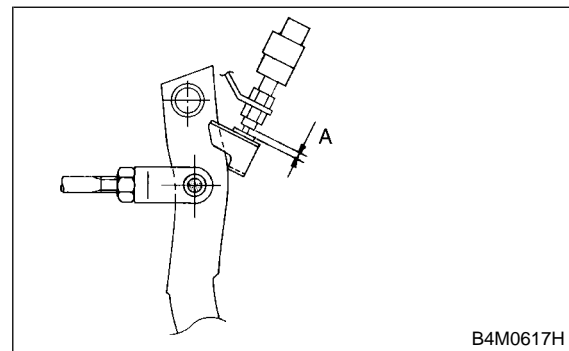

- 9) Apply grease to operating rod connecting pin to prevent it from wearing.
- 10) Bleed air from brake system.

**Tightening torque (Air bleeder screw):**

**8 N·m (0.8 kgf-m, 5.8 ft-lb)**

- 11) Conduct road tests to ensure brakes do not drag.

## C: INSPECTION S405166A10

### 1. OPERATION CHECK (WITHOUT GAUGES) S405166A1001

**CAUTION:**

When checking operation, be sure to securely apply the hand brake.

● **Checking without gauges**

This method cannot determine the exact portion which has failed, but it can provide a rough understanding of the nature of the failure if checking is conducted in accordance with the following procedures.

● **Air tightness check**

Start engine, and run it for 1 to 2 minutes, then turn it off. Depress brake pedal several times applying the same pedal force as that used in ordinary braking operations. The pedal stroke should be greatest on the 1st depression, and it should become smaller with each successive depression. If no change occurs in the pedal height while in a depressed state, brake booster is faulty.

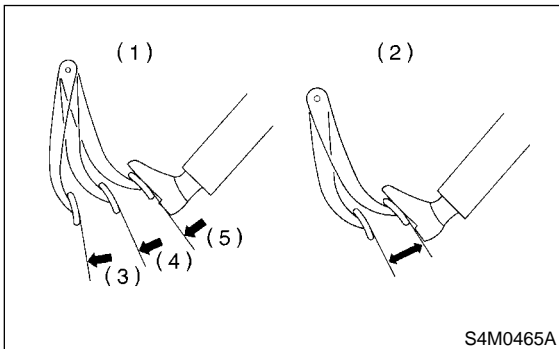

- (1) OK
- (2) NOT OK
- (3) 1st
- (4) 2nd
- (5) 3rd

**NOTE:**

- In the event of defective operation, inspect the condition of the check valve and vacuum hose.
- Replace them if faulty and conduct the test again.
- If no improvement is observed, check precisely with gauges.

● **Operation check**

1) With engine off, depress brake pedal several times applying the same pedal force and make sure that the pedal height does not vary with each depression of the pedal.

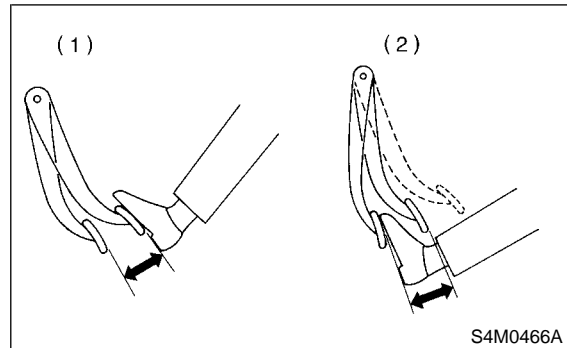

- (1) When engine is stopped
- (2) When engine is started

- 2) With brake pedal depressed, start engine.
- 3) As engine starts, brake pedal should move slightly toward the floor. If no change occurs in the pedal height, brake booster is faulty.

**NOTE:**

If faulty, check precisely with gauges.

● **Loaded air tightness check**

Depress brake pedal while engine is running, and turn off engine while the pedal is still depressed. Keep the pedal depressed for 30 seconds; if no change occurs in the pedal height, brake booster is functioning normally; if the pedal height increases, it is faulty.

**NOTE:**

If faulty, check precisely with gauges.

### 2. OPERATION CHECK (WITH GAUGES) S405166A1002

**CAUTION:**

When checking operation, be sure to securely apply the hand brake.

## ● Checking with gauges

Connect gauges as shown in Figure. After bleeding air from pressure gauges, proceed to each check.

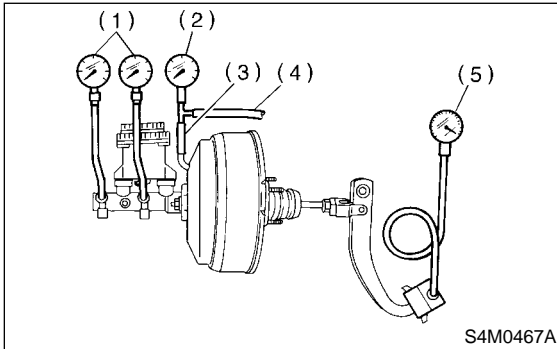

- (1) Pressure gauge
- (2) Vacuum gauge
- (3) Adapter hose
- (4) Vacuum hose
- (5) Pedal force gauge

## ● Air tightness check

1) Start engine and keep it running until a vacuum of 66.7 kPa (500 mmHg, 19.69 inHg) = point A is indicated on vacuum gauge. Do not depress brake pedal.

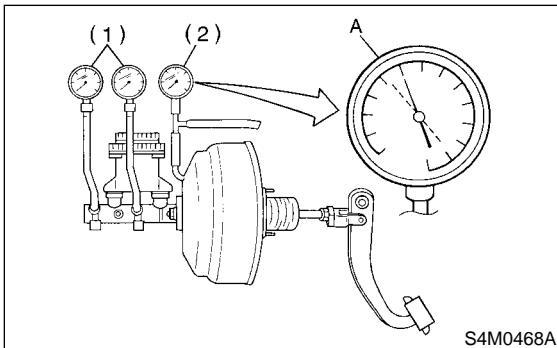

- (1) Pressure gauge
- (2) Vacuum gauge

2) Stop engine and watch the gauge. If the vacuum drop range is less than 3.3 kPa (25 mmHg, 0.98 inHg) within 15 seconds after stopping engine, brake booster is functioning properly. If defective, the cause may be one of those listed below.

- Check valve malfunction
- Leak from vacuum hose
- Leak from the shell jointed portion or stud bolt welded portion
- Damaged diaphragm
- Leak from valve body seal and bearing portion
- Leak from plate and seal assembly portion
- Leak from poppet valve assembly portion

## ● Loaded air tightness check

1) Start engine and depress brake pedal with pedal force of 196 N (20 kg, 44 lb). Keep engine running until a vacuum of 66.7 kPa (500 mmHg, 19.69 inHg) = point B is indicated on vacuum gauge while the pedal is still depressed.

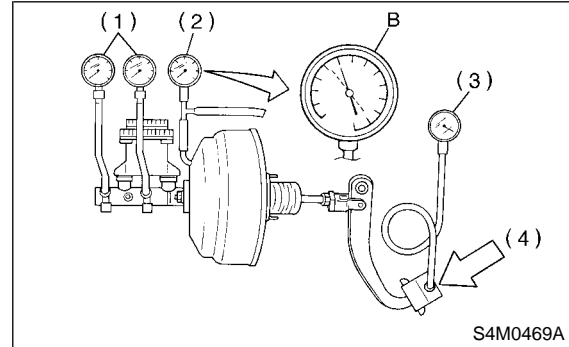

- (1) Pressure gauge
- (2) Vacuum gauge
- (3) Pedal force gauge
- (4) Depress

2) Stop engine and watch vacuum gauge. If the vacuum drop range is less than 3.3 kPa (25 mmHg, 0.98 inHg) within 15 seconds after stopping engine, brake booster is functioning properly. If defective, refer to "AIR TIGHTNESS CHECK". <Ref. to BR-42 INSPECTION, Brake Booster.>

## ● Lack of boosting action check

Turn off engine, and set the vacuum gauge reading at "0". Then, check the fluid pressure when brake pedal is depressed. The pressure must be greater than the standard value listed.

Brake pedal force	147 N (15 kgf, 33 lb)	294 N (30 kgf, 66 lb)
Fluid pressure	588 kPa (6 kg/cm <sup>2</sup> , 85 psi)	1,667 kPa (17 kg/cm <sup>2</sup> , 242 psi)

## ● Boosting action check

Set the vacuum gauge reading at 66.7 kPa (500 mmHg, 19.69 inHg) by running engine. Then, check the fluid pressure when brake pedal is depressed. The pressure must be greater than the standard value listed.

Brake pedal force	147 N (15 kgf, 33 lb)	294 N (30 kgf, 66 lb)
Fluid pressure	5,394 kPa (55 kg/cm <sup>2</sup> , 782 psi)	10,003 kPa (102 kg/cm <sup>2</sup> , 1,450 psi)

## 13. Proportioning Valve

S405167

### A: REMOVAL

S405167A18

#### With ABS model

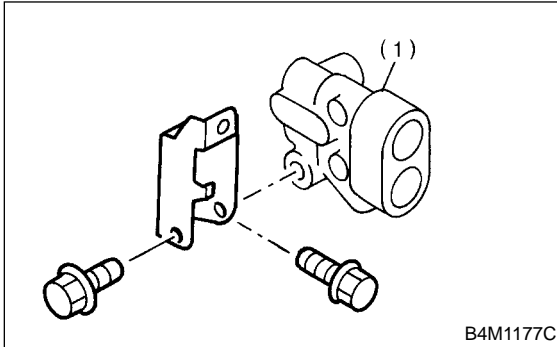

(1) Proportioning valve

#### Without ABS model

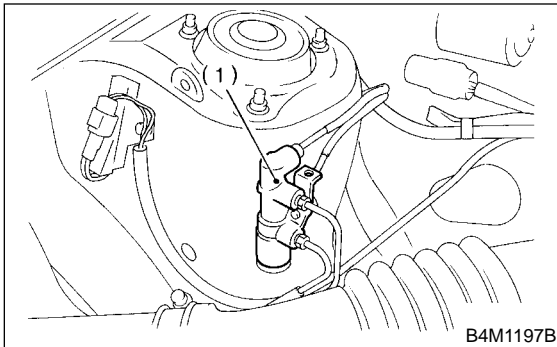

(1) Proportioning valve

- 1) Pull up parking brake lever, and block the tires.
- 2) Remove brake pipe from proportioning valve at four places.
- 3) Remove proportioning valve from its bracket.

#### CAUTION:

**Do not disassemble or adjust the proportioning valve. (The proportioning valve must be replaced as an assembly.)**

### B: INSTALLATION

S405167A11

- 1) Install proportioning valve to bracket.
- 2) Connect brake pipes correctly to proportioning valve.
- 3) Bleed air, then check each joint of brake pipe for oil leaks.

#### Tightening torque:

**Proportioning valve to brake pipe flare nut:**

**15 N·m (1.5 kgf·m, 10.8 ft·lb)**

**Proportioning valve to bracket:**

**18 N·m (1.8 kgf·m, 13.0 ft·lb)**

### C: INSPECTION

S405167A10

- 1) Install the oil pressure gauges to measure the master cylinder fluid pressure (front wheel brake fluid pressure) and rear wheel cylinder fluid pressure.
- 2) Bleed air from the oil pressure gauges.
- 3) Check the master cylinder fluid pressure and rear wheel cylinder fluid pressure.

The standard values are shown in Figure.

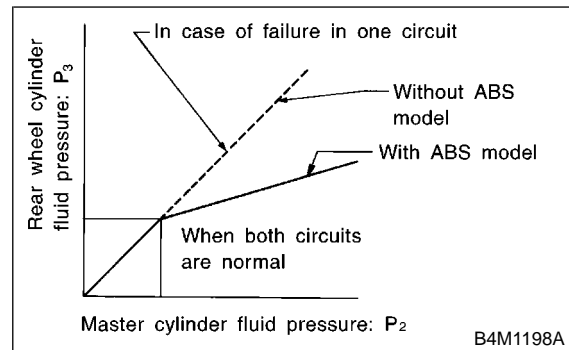

- 4) For the oil pressure in case of split point, refer to "SPECIFICATIONS".  
<Ref. to BR-2 SPECIFICATIONS, General Description.>

## 14. Brake Fluid S405162

### A: INSPECTION S405162A10

- 1) Check that brake fluid level remains between "MIN" and "MAX". If out of the specified range, refill or drain fluid. If fluid level becomes close to "MIN", refill fluid.
- 2) Check fluid for discoloration. If fluid color has excessively changed, drain the fluid and refill with new fluid.

### B: REPLACEMENT S405162A20

#### CAUTION:

- To always maintain the brake fluid characteristics, replace the brake fluid according to maintenance schedule or earlier than that when used in severe condition.
- The FMVSS No. 116, fresh DOT3 or 4 brake fluid must be used.
- Cover bleeder with waste cloth, when loosening it, to prevent brake fluid from being splashed over surrounding parts.
- Avoid mixing different brands of brake fluid to prevent degrading the quality of the fluid.
- Be careful not to allow dirt or dust to get into the reservoir tank.

#### NOTE:

- During bleeding operation, keep the brake reservoir tank filled with brake fluid to eliminate entry of air.
- Brake pedal operating must be very slow.
- For convenience and safety, two people should do the work.
- The amount of brake fluid required is approximately 500 ml (16.9 US fl oz, 17.6 Imp fl oz) for total brake system.

- 1) Either jack-up vehicle and place a safety stand under it, or lift-up vehicle.
- 2) Remove both front and rear wheels.
- 3) Draw out the brake fluid from master cylinder with syringe.
- 4) Refill reservoir tank with recommended brake fluid.

#### Recommended brake fluid:

**FMVSS No. 116, fresh DOT3 or 4 brake fluid**

- 5) Install one end of a vinyl tube onto the air bleeder of and insert the other end of the tube into a container to collect the brake fluid.

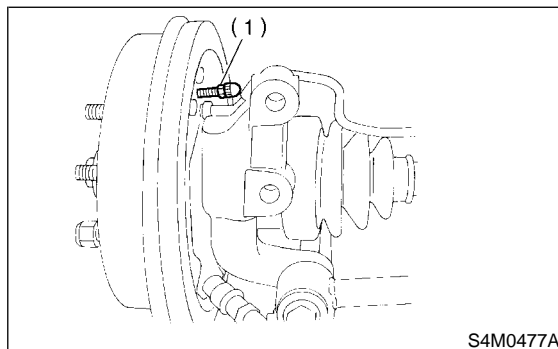
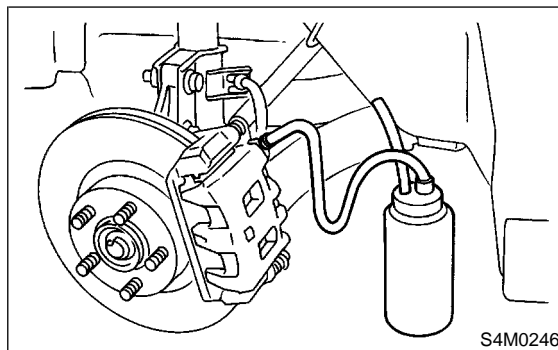

#### CAUTION:

**Brake fluid replacement sequence; (A) Front right → (B) Rear left → (C) Front left → (D) Rear right**

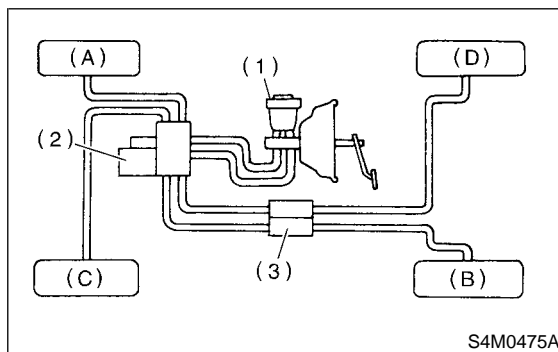

- (1) Master cylinder
- (2) Hydraulic unit
- (3) Proportioning valve

- 6) Instruct your co-worker to depress the brake pedal slowly two or three times and then hold it depressed.
- 7) Loosen bleeder screw approximately 1/4 turn until a small amount of brake fluid drains into container, and then quickly tighten screw.
- 8) Repeat steps 6) and 7) above until there are no air bubbles in drained brake fluid and new fluid flows through vinyl tube.

# BRAKE FLUID

Brake

---

## NOTE:

Add brake fluid as necessary while performing the air bleed operation, in order to prevent the tank from running short of brake fluid.

9) After completing the bleeding operation, hold brake pedal depressed and tighten screw and install bleeder cap.

***Tightening torque (Bleeder screw):***  
***8 N·m (0.8 kgf-m, 5.8 ft-lb)***

10) Bleed air from each wheel cylinder using the same procedures as described in steps 6) through 7) above.

11) Depress brake pedal with a force of approximately 294 N (30 kgf, 66 lb) and hold it there for approximately 20 seconds. At this time check pedal to see if it shows any unusual movement.

Visually inspect bleeder screws and brake pipe joints to make sure that there is no fluid leakage.

12) Install wheels, and drive vehicle for a short distance between 2 to 3 km (1 to 2 miles) to make sure that brakes are operating properly.

## 15. Air Bleeding S405163

### A: PROCEDURE S405163E45

#### CAUTION:

- The FMVSS No. 116, fresh DOT3 or 4 brake fluid must be used.
- Cover bleeder with waste cloth when loosening it to prevent brake fluid from being splashed over surrounding parts.
- Avoid mixing different brands of brake fluid to prevent degrading the quality of the fluid.
- Be careful not to allow dirt or dust to get into the reservoir tank.

#### NOTE:

- Start with the brakes (wheels) connected to the secondary chamber of the master cylinder.
- The time interval between two brake pedal operations (from the time when the pedal is released to the time when it is depressed another time) shall be approximately 3 seconds.
- The air bleeder on each brake shall be released for 1 to 2 seconds.

### 1. MASTER CYLINDER S405163E4501

#### NOTE:

- If master cylinder is disassembled or reservoir tank is empty, bleed master cylinder.
- During bleeding operation, keep the brake reservoir tank filled with brake fluid to eliminate entry of air.
- Brake pedal operating must be very slow.
- For convenience and safety, two people should do the work.

- 1) Loosen wheel nuts, jack-up vehicle, support it with safety stands, and remove wheel.
- 2) Disconnect brake line at primary and secondary sides.
- 3) Put plastic bag cover on the master cylinder.
- 4) Carefully depress and hold brake pedal.

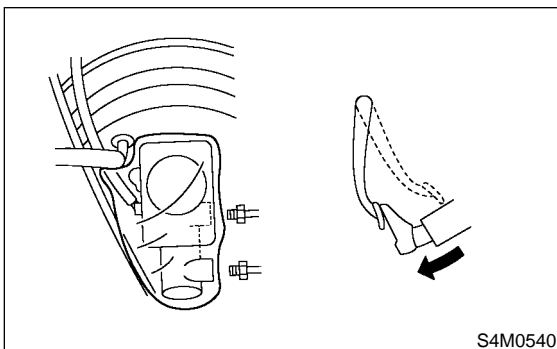

- 5) Close outlet plug with your finger, and release brake pedal.

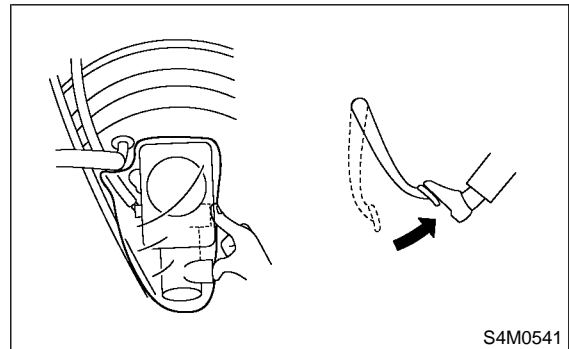

- 6) Repeat items 3) and 4), until brake fluid come out of all outlet port.
- 7) Remove the plastic bag cover.
- 8) Install brake pipes to master cylinder.

#### **Tightening torque:**

**8 N·m (0.8 kgf·m, 5.8 ft·lb)**

- 9) Cleanly wash away brake fluid spill on master cylinder etc.
- 10) Bleed air from brake system. <Ref. to BR-47, BRAKE LINE, PROCEDURE, Air Bleeding.>

### 2. BRAKE LINE S405163E4502

#### NOTE:

- During bleeding operation, keep the brake reservoir tank filled with brake fluid to eliminate entry of air.
- Brake pedal operating must be very slow.
- For convenience and safety, two people should do the work.

- 1) Make sure that there is no leak from joints and connections of the brake system.
- 2) Fit one end of vinyl tube into the air bleeder and put the other end into a brake fluid container.

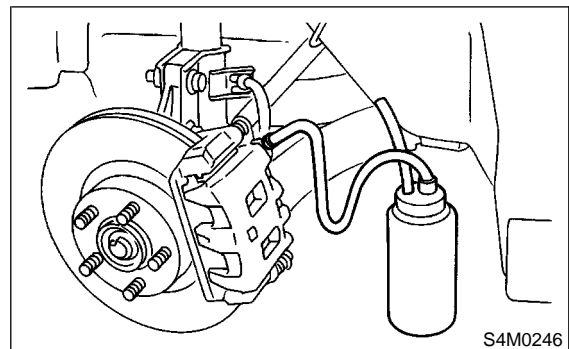



# AIR BLEEDING

Brake

## CAUTION:

**Brake fluid replacement sequence; (A) Front right → (B) Rear left → (C) Front left → (D) Rear right**

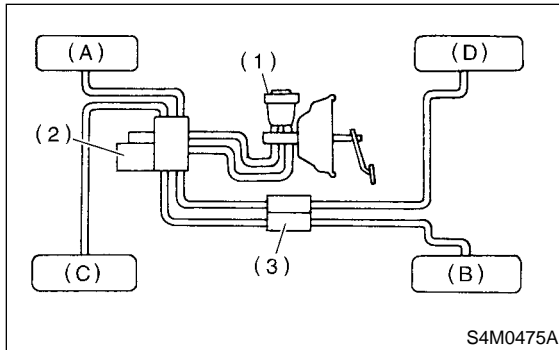

- (1) Master cylinder
- (2) Hydraulic unit
- (3) Proportioning valve

3) Slowly depress the brake pedal and keep it depressed. Then, open the air bleeder to discharge air together with the fluid.

Release air bleeder for 1 to 2 seconds.

Next, with the bleeder closed, slowly release the brake pedal.

Repeat these steps until there are no more air bubbles in the vinyl tube.

Allow 3 to 4 seconds between two brake pedal operations.

## CAUTION:

**Cover bleeder with waste cloth, when loosening it, to prevent brake fluid from being splashed over surrounding parts.**

## NOTE:

Brake pedal operating must be very slow.

4) Tighten air bleeder securely when no air bubbles are visible.

## **Air bleeder tightening torque:**

**8 N·m (0.8 kgf-m, 5.8 ft-lb)**

5) Perform these steps for the brakes connecting to the secondary chamber of master cylinder, first, and then for the ones connecting to primary chamber. With all procedures completed, fully depress the brake pedal and keep it in that position for approximately 20 seconds to make sure that there is no leak evident in the entire system.

6) Check the pedal stroke.

While the engine is idling, depress the brake pedal with a 490 N (50 kgf, 110 lb) load and measure the distance between the brake pedal and steering wheel. With the brake pedal released, measure the distance between the pedal and steering wheel again. The difference between the two measurements must be more than specified.

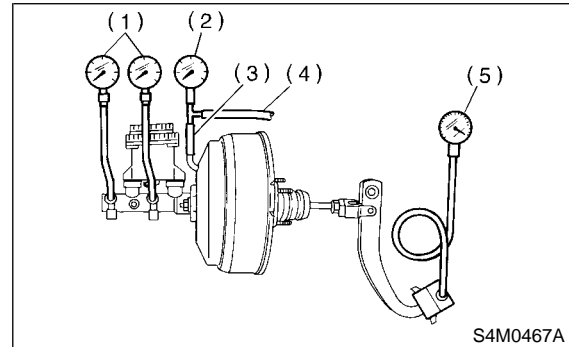

- (1) Steering wheel
- (2) Toe board

## **Specified pedal stroke:**

### **Without ABS**

**90 mm (3.54 in)**

### **With ABS**

**95 mm (3.74 in)**

**When depressing brake pedal with a 490 N (50 kgf, 110 lb) load.**

7) If the distance is more than specifications, there is a possibility that air is in the brake line. Bleed brake line until pedal stroke meets the specification.

8) Operate hydraulic control unit in the sequence control mode. (Only vehicle equipped with ABS)  
<Ref. to ABS-11 ABS Sequence Control.>

9) Recheck the brake stroke.

10) If the distance is more than specifications, there is a possibility air is in the inside of the hydraulic unit. Repeat above steps 2) to 9) above until pedal stroke meets the specification.

11) Add brake fluid to the required level (MAX. level) of reservoir tank.

12) As a final step, test run the vehicle at low speed and apply brakes relatively hard 2 to 3 times to ensure that brakes provide normal braking action on all four wheels without dragging and uneven braking.

## 16. Brake Hose S405164

### A: REMOVAL S405164A18

- 1) Loosen wheel nuts, jack-up vehicle, support it with safety stands, and remove wheel.
- 2) Separate brake pipe from brake hose.  
(Always use flare nut wrench and be careful not to deform flare nut.)

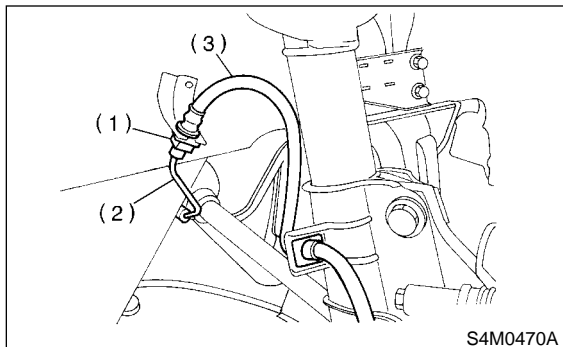

- (1) Clamp
- (2) Brake pipe
- (3) Brake hose

- 3) Pull out clamp to remove brake hose.
- 4) Remove clamp at strut and union bolt.

### B: INSTALLATION S405164A11

#### 1. FRONT BRAKE HOSE S405164A1101

- 1) Route end of brake hose (on caliper side) through hole in brake hose bracket at strut location.
- 2) Tighten end of brake hose at caliper using a union bolt.

#### **Tightening torque:**

**18 N·m (1.8 kgf-m, 13.0 ft-lb)**

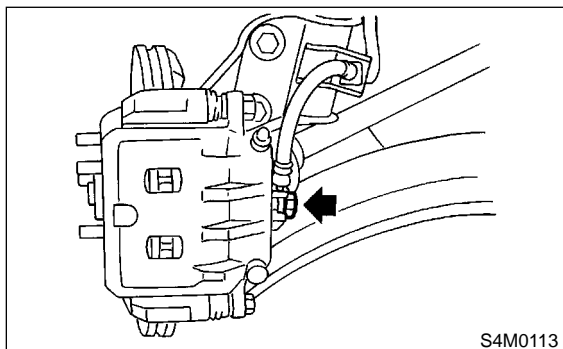

- 3) Secure middle fitting of brake hose to bracket at strut location using a clamp.
- 4) Position disc in straight-forward direction and route brake hose through hole in bracket on wheel apron side.

#### **CAUTION:**

**Be sure brake hose is not twisted.**

- 5) Temporarily tighten flare nut to connect brake pipe and hose.
- 6) Fix brake hose with clamp at wheel apron bracket.
- 7) While holding hexagonal part of brake hose fitting with a wrench, tighten flare nut to the specified torque.

#### **Tightening torque (Brake pipe flare nut):**

**15 N·m (1.5 kgf-m, 10.8 ft-lb)**

- 8) Bleed air from the brake system. <Ref. to BR-47, Air Bleeding.>

### 2. REAR BRAKE HOSE S405164A1102

- 1) Pass brake hose through the hole of bracket, and lightly tighten flare nut to connect brake pipe.
- 2) Insert clamp upward to fix brake hose.
- 3) While holding hexagonal part of brake hose fitting with a wrench, tighten flare nut to the specified torque.

#### **Tightening torque (Brake pipe flare nut):**

**15 N·m (1.5 kgf-m, 10.8 ft-lb)**

- 4) Bleed air from the brake system. <Ref. to BR-47, Air Bleeding.>

### C: INSPECTION S405164A10

Ensure there are no cracks, breakage, or damage on hoses. Check joints for fluid leakage. If any cracks, breakage, damage or leakage is found, repair or replace hose.

## 17. Brake Pipe S405165

### A: REMOVAL S405165A18

**NOTE:**

Airbag system wiring harness is routed near the center brake pipe.

**CAUTION:**

- All Airbag system wiring harness and connectors are colored yellow. Do not use electrical test equipment on these circuits.
- Be careful not to damage Airbag system wiring harness when servicing the center brake pipe.
- When removing the brake pipe, make sure that it is not bent.

### B: INSTALLATION S405165A11

**NOTE:**

Airbag system wiring harness is routed near the center brake pipe.

**CAUTION:**

- All Airbag system wiring harness and connectors are colored yellow. Do not use electrical test equipment on these circuits.
- Be careful not to damage Airbag system wiring harness when servicing the center brake pipe.
- When installing the brake pipe, make sure that it is not bent.
- After installing the brake pipe and hose, bleed the air.
- After installing the brake hose, make sure that it does not touch the tire or suspension assembly, etc.

***Brake pipe tightening torque:***

***15 N·m (1.5 kgf-m, 10.8 ft-lb)***

### C: INSPECTION S405165A10

Ensure there are no cracks, breakage, or damage on pipes. Check joints for fluid leakage. If any cracks, breakage, damage or leakage is found, repair or replace pipe.

**NOTE:**

Use a mirror when inspecting low-visible part or back side.

## 18. Hill Holder S405661

### A: REMOVAL S405661A18

#### 1. PHV (PRESSURE HOLD VALVE) S405661A1801

- 1) Remove air cleaner case. (Non-turbo model) <Ref. to IN(SOHC)-7, REMOVAL, Air Cleaner Case.>
- 2) Remove intercooler. (Turbo model) <Ref. to IN(DOHC TURBO)-10, REMOVAL, Intercooler.>
- 3) Drain brake fluid from reservoir of master cylinder.
- 4) Remove adjusting nut and lock nut.

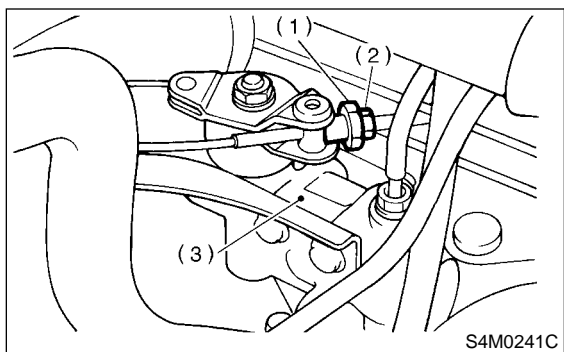

- (1) Adjusting nut
- (2) Lock nut
- (3) PHV

- 5) Remove cable clamp, and disconnect PHV cable from PHV.

**CAUTION:**  
Carefully protect boots and inner cable from damage when disconnecting PHV cable.

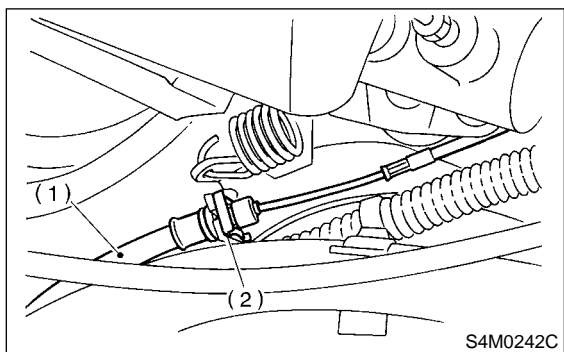

- (1) PHV cable
- (2) Clamp

- 6) Disconnect brake pipes from PHV.

**CAUTION:**

- Pay attention not to drop brake fluid onto body painting since it may dissolve paint.
- Pay attention not to damage hexagonal head of flare nut by using pipe wrench without fail.

- 7) Detach PHV along with support from side frame.

**CAUTION:**  
Exercise utmost care to prevent foreign matter from entering into PHV when removing it.

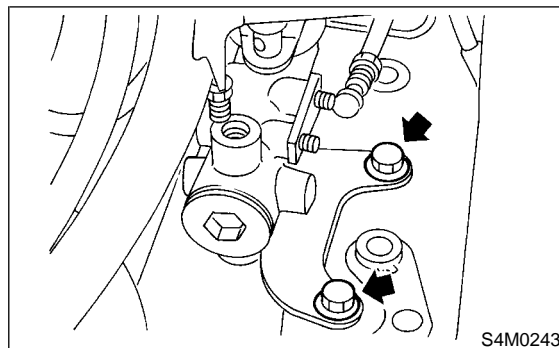

#### 2. PHV CABLE S405661A1802

- 1) Remove air cleaner case. (Non-turbo model) <Ref. to IN(SOHC)-7, REMOVAL, Air Cleaner Case.>
- 2) Remove intercooler. (Turbo model) <Ref. to IN(DOHC TURBO)-10, REMOVAL, Intercooler.>
- 3) Remove adjusting nut and lock nut.

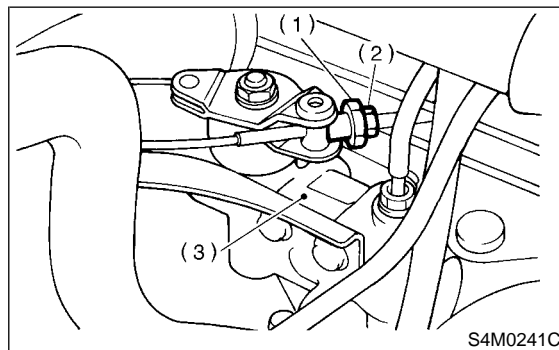

- (1) Adjusting nut
- (2) Lock nut
- (3) PHV

4) Remove cable clamp, and disconnect PHV cable from PHV.

**CAUTION:**

Carefully protect boot and inner cable from damage when disconnecting PHV cable.

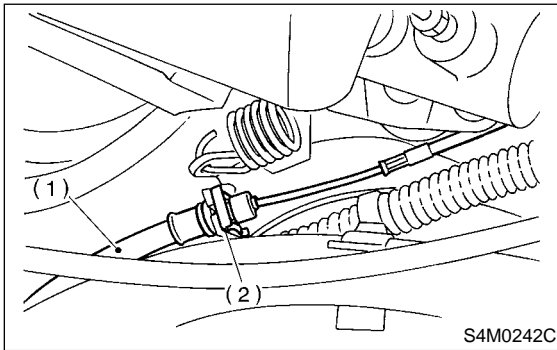

- (1) PHV cable
- (2) Clamp

5) Remove cable clamp from clutch pedal bracket.

**LHD model**

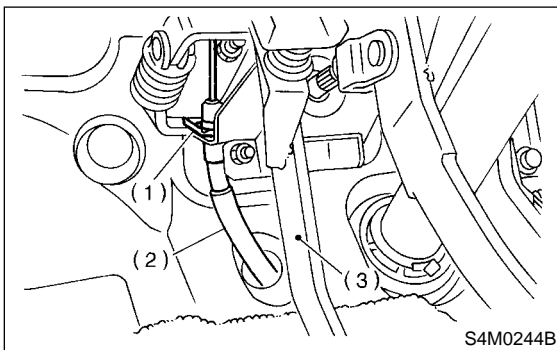

- (1) Clamp
- (2) PHV cable
- (3) Clutch pedal

**RHD model**

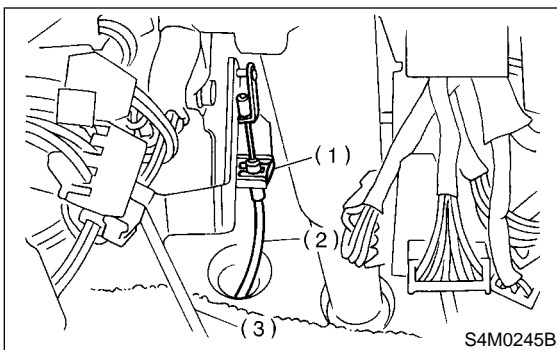

- (1) Clamp
- (2) PHV cable
- (3) Clutch pedal

6) Remove PHV cable.

**B: INSTALLATION** S405661A11

**1. PHV (PRESSURE HOLD VALVE)** S405661A1101

1) Install PHV onto side frame.

**Tightening torque:**

**18 N·m (1.8 kgf-m, 13.0 ft-lb)**

2) Connect brake pipes to PHV.

**Tightening torque:**

**15 N·m (1.5 kgf-m, 10.8 ft-lb)**

**CAUTION:**

Confirm that brake pipes are not deformed and/or damaged. Replace them with new ones if necessary.

3) Install PHV cable to PHV.

**CAUTION:**

If cable clamp (and clips) is damaged, replace it with a new one.

4) Connect PHV cable with clips.

**NOTE:**

Avoid sharp bending of PHV cable as it may cause breakage.

5) Apply grease to the following points.

- Hook portion of return spring
- Cable end portion of lever

**Grease:**

**SUNLIGHT 2 (Part No. 003602010)**

6) Be sure to bleed air from the brake system.

7) Adjust PHV cable. <Ref. to BR-53 ADJUSTMENT, Hill Holder.>

**CAUTION:**

After replacing PHV cable with new one, operate clutch pedal about 30 times as a running-in operation prior to adjustment.

8) Install air cleaner case. (Non-turbo model) <Ref. to IN(SOHC)-7, REMOVAL, Air Cleaner Case.>

9) Install intercooler. (Turbo model) <Ref. to IN(DOHC TURBO)-10, INSTALLATION, Intercooler.>

**2. PHV CABLE** S405661A1102

1) Install PHV cable in the reverse order of removal.

**CAUTION:**

● If cable clamp is damaged, replace it with a new one.

● Avoid sharp bending of PHV cable as it may cause breakage.

2) Apply grease to the following points.

- Hook portion of return spring
- Cable end portion of lever

**Grease:****SUNLIGHT 2 (Part No. 003602010)**

3) Adjust PHV cable. <Ref. to BR-53 ADJUSTMENT, Hill Holder.>

**CAUTION:**

**After replacing PHV cable with new one, operate clutch pedal about 30 times as a running-in operation prior to adjustment.**

4) Install air cleaner case. (Non-turbo model) <Ref. to IN (SOHC)-7, INSTALLATION, Air Cleaner Case.>

5) Install intercooler. (Turbo model) <Ref. to IN (DOHC TURBO)-10, INSTALLATION, Intercooler.>

**C: INSPECTION**

S405661A10

Check up removed parts as follows, and replace defective ones.

- 1) Check if boots of PHV cable are damaged or degraded, and if inner cable is damaged or corroded.
- 2) Check if return spring is worn out, damaged or corroded.
- 3) Confirm that rolling sound of ball is heard with PHV inclined and lever rotates smoothly.

**CAUTION:**

**Never disassemble PHV. Replace entire PHV assembly if necessary.**

**D: ADJUSTMENT**

S405661A01

Confirm stopping and starting performances by activating hill holder on an uphill road of 3° or higher inclination.

1) If vehicle does not stop;

Tighten adjusting nut of PHV cable.

2) If vehicle does not start properly;

● Case A — When hill holder is released later than engagement of clutch pedal (Engine tends to stall.):

Loosen adjusting nut gradually until smooth starting is enabled.

● Case B — When hill holder is released earlier than engagement of clutch pedal (Vehicle slips down slightly.):

Tighten adjusting nut so that hill holder is released later than engagement of clutch pedal (status in Case A). Then make adjustment the same as in Case A.

**CAUTION:**

**Whenever turning adjusting nut, prevent PHV cable from revolving.**

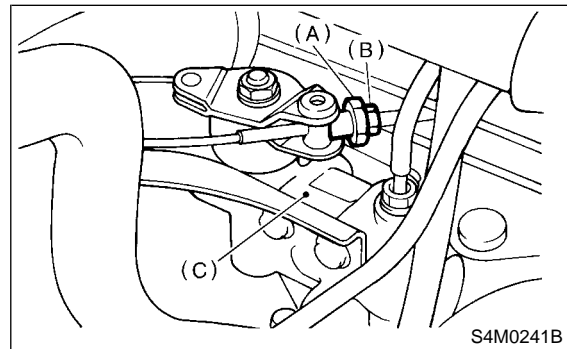

S4M0241B

- (1) Adjusting nut
- (2) Lock nut
- (3) PHV

3) Tighten lock nut.

**Tightening torque:**

**3.4 N·m (0.35 kgf-m, 2.5 ft-lb)**

## 19. Brake Pedal S405541

### A: REMOVAL S405541A18

#### 1. MT MODEL S405541A1801

##### ● LHD model

- 1) Pull up parking brake lever and block tires.
- 2) Disconnect battery ground terminal from battery.
- 3) Remove steering column.  
<Ref. to PS-30 REMOVAL, Tilt Steering Column.>
- 4) Disconnect connectors from stop light and clutch switches.
- 5) Remove snap pins which secure lever to push rod and operating rod.
- 6) Remove clevis pins which secure lever to push rod and operating rod.

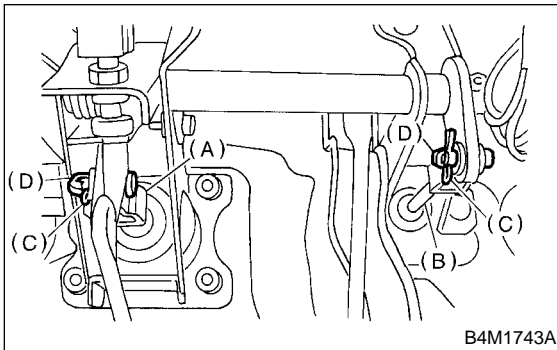

B4M1743A

- (A) Operating rod
- (B) Push rod
- (C) Snap pin
- (D) Clevis pin

- 7) Remove PHV adjusting nut and lock nut.

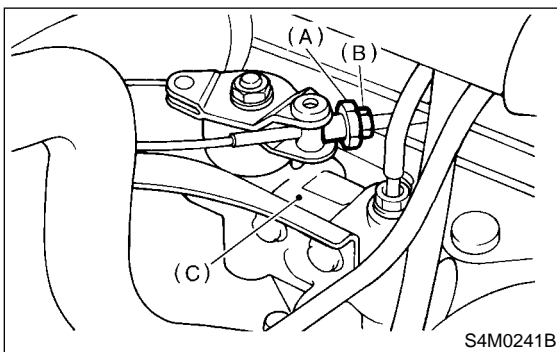

S4M0241B

- (A) Adjusting nut
- (B) Lock nut
- (C) PHV

- 8) Remove cable clamp, and disconnect PHV cable from PHV.

#### CAUTION:

Carefully protect boot and inner cable from damage when disconnecting PHV cable.

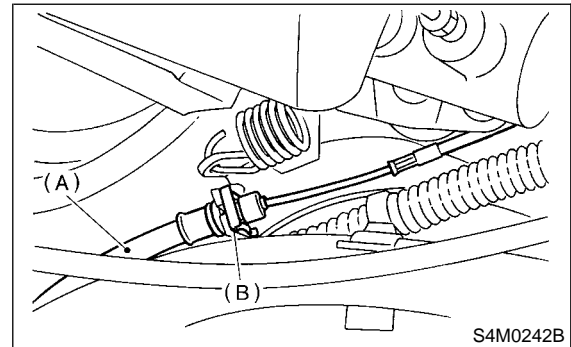

S4M0242B

- (A) PHV cable
- (B) Clamp

- 9) Remove nut which secures clutch master cylinder.

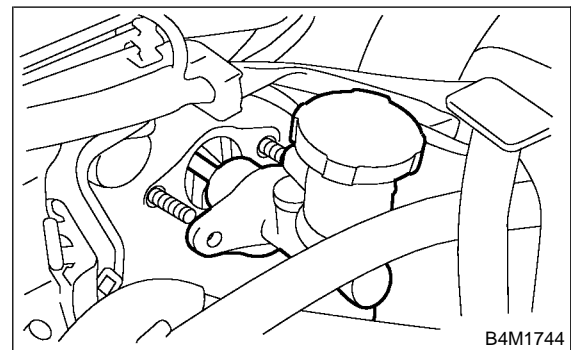

B4M1744

- 10) Remove bolts and nuts which secure brake and clutch pedals, and remove pedal assembly.

● **RHD model**

- 1) Pull up parking brake lever.
- 2) Disconnect battery ground terminal from battery.
- 3) Disconnect accelerator cable from throttle body.

**CAUTION:**

**Be careful not to kink accelerator cable.**

- 4) Remove instrument panel lower cover from instrument panel.
- 5) Remove clevis pin which secures brake pedal to brake booster operating rod. Also disconnect electrical connectors (for stop light switch, etc.).
- 6) Disconnect accelerator cable from accelerator pedal lever.

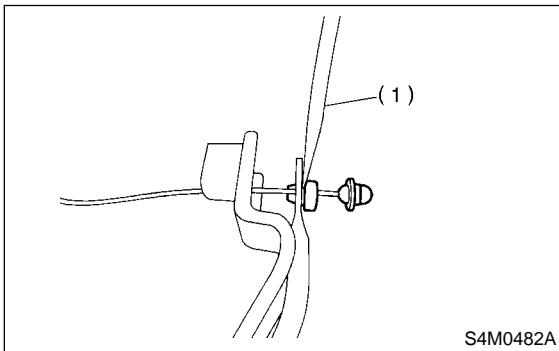

(1) Slot type screwdriver

- 7) Remove the casing cap out of the toe board by turning it clockwise.

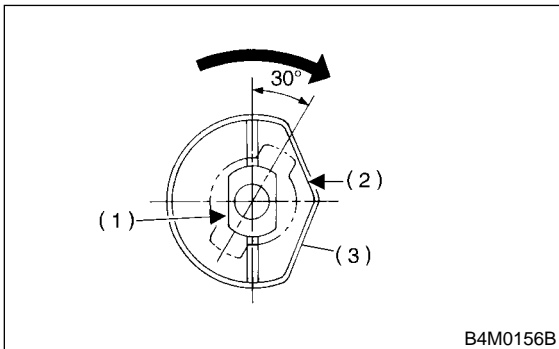

- (1) Accelerator cable
- (2) Toe board hole
- (3) Casing cap

- 8) Pull out the cable from the toe board hole.
- 9) Disconnect stop light switch connector.

- 10) Remove nuts and bolts which secure pedal bracket.

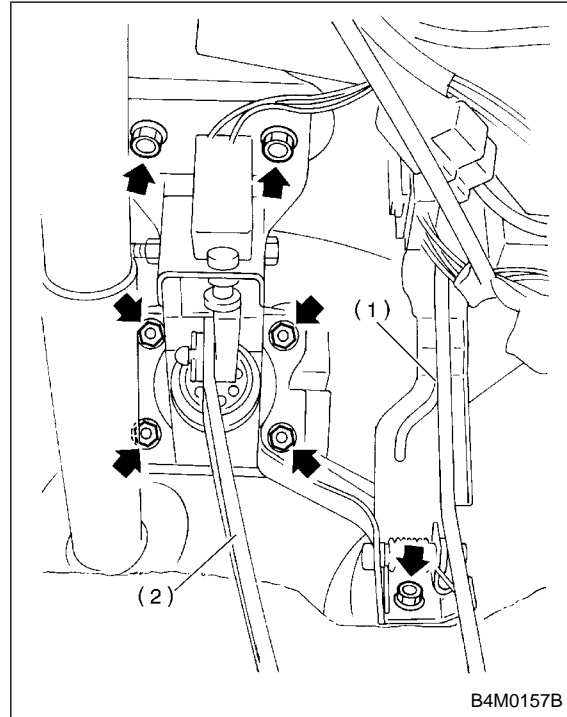

- (1) Accelerator pedal
- (2) Brake pedal



# BRAKE PEDAL

Brake

## 2. AT MODEL S405541A1802

### ● LHD model

- 1) Pull up parking brake lever.
- 2) Disconnect battery ground terminal from battery.
- 3) Remove instrument panel lower cover from instrument panel.
- 4) Remove clevis pin which secures brake pedal to brake booster operating rod. Also disconnect stop light switch connector.
- 5) Remove two bolts and four nuts which secure brake pedal to pedal.

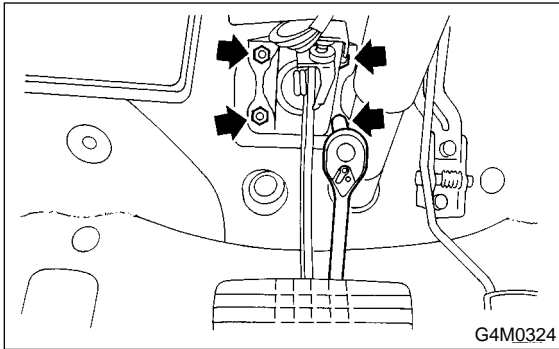

### ● RHD model

#### NOTE:

For removal procedures, refer to "MT MODEL".  
<Ref. to BR-54 MT MODEL, REMOVAL, Brake Pedal.>

## B: INSTALLATION S405541A11

- 1) Install in the reverse order of removal.

#### CAUTION:

- Be careful not to bend clutch cable too much.
- Never fail to cover outer cable end with boot.
- Be careful not to kink accelerator cable.
- Make sure that holder and casing cap are securely connected. (LHD model only)

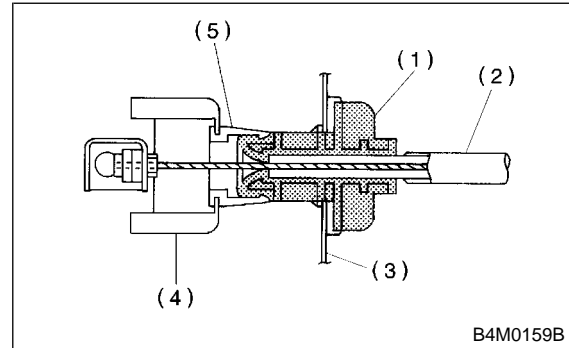

- (1) Casing cap
- (2) Accelerator cable
- (3) Toe board
- (4) Accelerator pedal bracket
- (5) Holder

- 2) Adjustment of clutch pedal <Ref. to BR-58 ASSEMBLY, Brake Pedal.>
- 3) Inspect after pedal installation <Ref. to BR-59 INSPECTION, Brake Pedal.>

## C: DISASSEMBLY S405541A06

### 1. MT MODEL S405541A0601

#### ● LHD model

- 1) Remove the stop light switch.
- <Ref. to BR-60 REMOVAL, Stop Light Switch.>
- 2) Remove the clutch pedal.
- <Ref. to CL-38 DISASSEMBLY, Clutch Pedal.>
- 3) Remove the clutch master cylinder bracket.

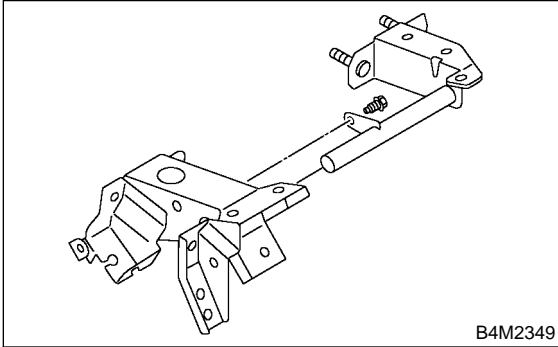

- 4) Remove bushing, spring and stopper.

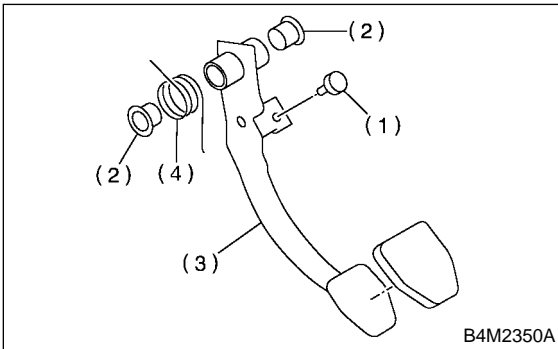

- (1) Stopper
- (2) Bushing
- (3) Brake pedal
- (4) Brake pedal spring

- 5) Remove the brake pedal pad.

#### ● RHD model

- 1) Remove the stop light switch and kick-down switch.
- 2) Remove clip, bushing, accelerator spring and accelerator pedal.

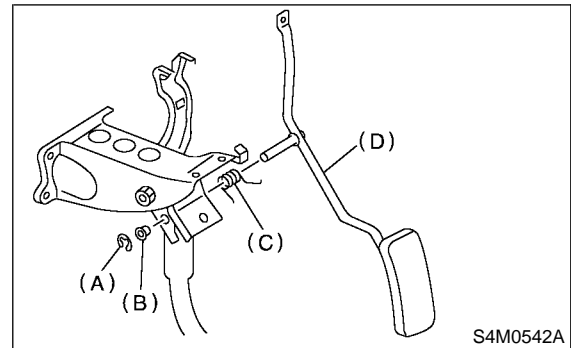

- (1) Clip
- (2) Bushing
- (3) Accelerator spring
- (4) Accelerator pedal

- 3) Unbolt, and then remove the brake pedal.

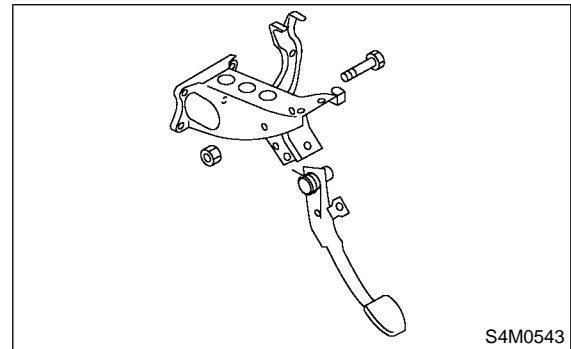

- 4) Remove spacer, bushing, brake pedal spring and brake pedal.

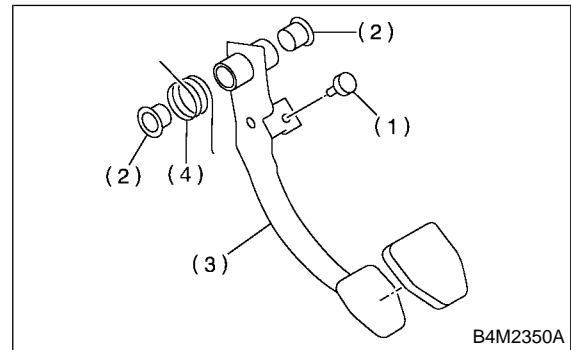

- (1) Stopper
- (2) Bushing
- (3) Brake pedal
- (4) Brake pedal spring

- 5) Remove the brake pedal pad.

# BRAKE PEDAL

Brake

## 2. AT MODEL S405541A0602

- 1) Remove the brake switch.
- 2) Unbolt, and then remove the brake pedal.

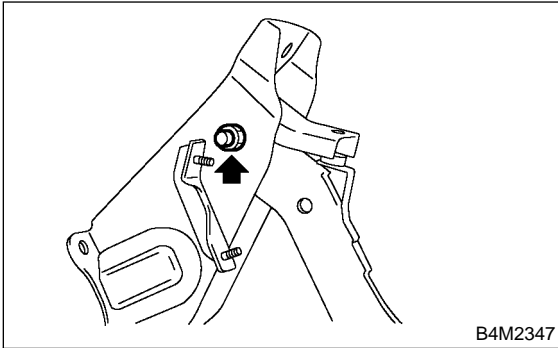

- 3) Remove bushing, spacer and spring.

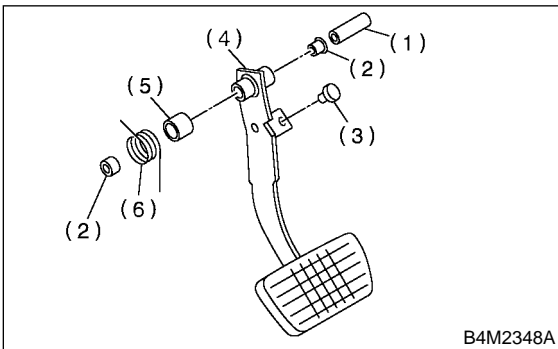

- (1) Spacer
- (2) Bushing
- (3) Stopper
- (4) Brake pedal
- (5) Brake spacer
- (6) Brake pedal spring

- 4) Remove the brake pedal pad.

## D: ASSEMBLY S405541A02

- 1) Attach stop light switch, etc. to pedal bracket temporarily.
- 2) Clean inside of bores of clutch pedal and brake pedal, apply grease, and set bushings into bores.
- 3) Align bores of pedal bracket, clutch pedal and brake pedal, attach brake pedal return spring and clutch pedal effort reducing spring (vehicle with hill holder), and then install pedal bolt.

### NOTE:

Clean up inside of bushings and apply grease before installing spacer.

### Tightening torque:

**T: 29 N·m (3.0 kgf-m, 21.7 ft-lb)**

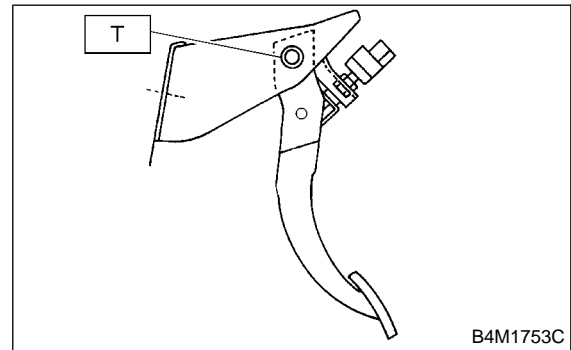

- 4) Set brake pedal position by adjusting position of stop light switch.

### Pedal position: L

#### LHD model

**125.9 mm (4.96 in)**

#### RHD model

**154.9 mm (6.10 in)**

### Tightening torque:

**T: 8 N·m (0.8 kgf-m, 5.8 ft-lb)**

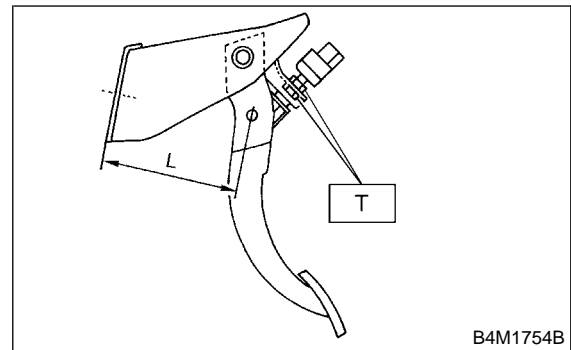

## E: INSPECTION

S405541A10

1) Move brake and clutch pedal pads in the lateral direction with a force of approximately 10 N (1 kgf, 2 lb) to ensure pedal deflection is in specified range.

### CAUTION:

If excessive deflection is noted, replace bushings with new ones.

### Deflection of brake and clutch pedal:

#### Service limit

5.0 mm (0.197 in) or less

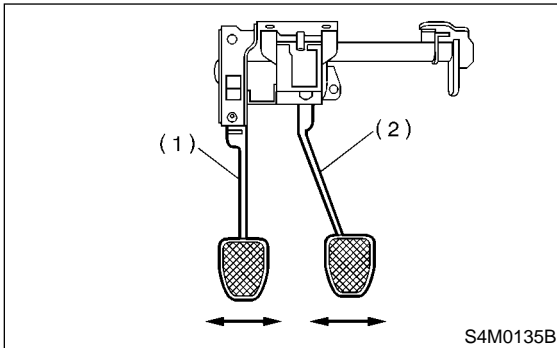

- (1) Clutch pedal
- (2) Brake pedal

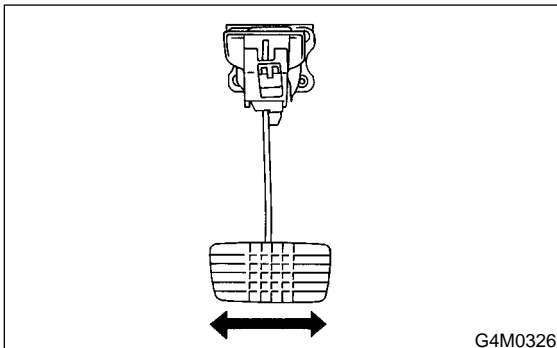

2) Check position of pedal pad.

### Pedal height: L

148 mm (5.83 in)

### Brake pedal free play: A

1 — 3 mm (0.04 — 0.12 in) [Depress brake pedal pad with a force of less than 10 N (1 kgf, 2 lb).]

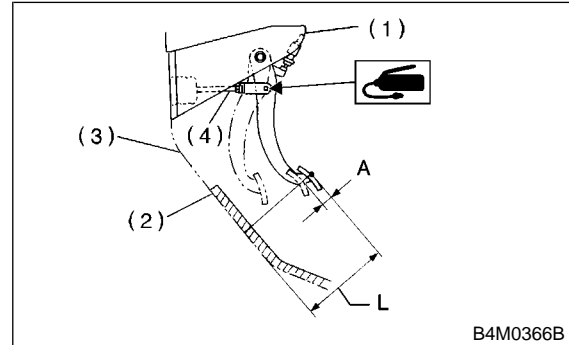

- (1) Stop light switch
- (2) Mat
- (3) Toe board
- (4) Brake booster operating rod

3) If it is not in specified value, adjust it by adjusting brake booster operating rod length.

# STOP LIGHT SWITCH

Brake

## 20. Stop Light Switch S405542

### A: REMOVAL S405542A18

- 1) Disconnect ground terminal from battery.
- 2) Disconnect stop light switch connector.
- 3) Loosen nuts, and unscrew stop light switch to remove.

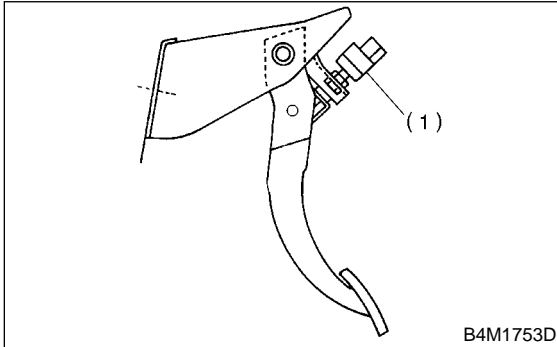

(1) Stop light switch

### B: INSTALLATION S405542A11

- 1) Screw the stop light switch onto a bracket and secure it temporarily with a nut.
  - 2) Adjust stop light switch position, and then tighten the nut.
- <Ref. to BR-61 ADJUSTMENT, Stop Light Switch.>

**Tightening torque:**  
**8 N·m (0.8 kgf-m, 5.8 ft-lb)**

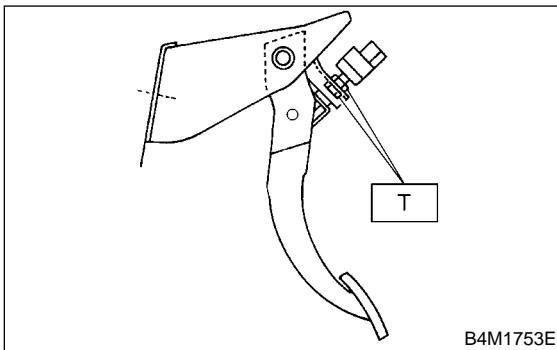

### C: INSPECTION S405542A10

- 1) If stop light switch does not operate properly (or if it does not stop at the specified position), replace with a new one.

**Specified position: L**  
 **$2^{+1.5/0} \text{ mm } (0.079^{+0.059/0} \text{ in})$**

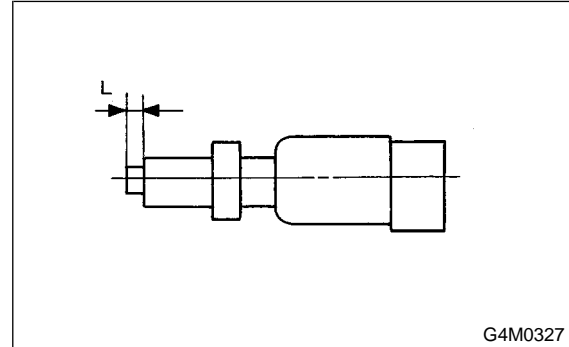

- 2) Measure the clearance between threaded end of stop light switch and stopper.

**CAUTION:**  
**Be careful not to rotate stop light switch.**

**Stop light switch clearance: A**  
**0.3 mm (0.012 in)**

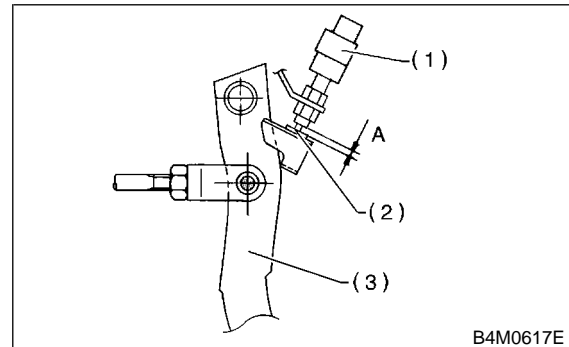

- (1) Stop light switch
- (2) Stopper
- (3) Brake pedal

- 3) If it is not in specified value, adjust it by adjusting position of stop light switch.

**CAUTION:**  
**Be careful not to rotate stop light switch.**

## D: ADJUSTMENT S405542A01

Loosen the lock nut, and adjust stop light switch position until the clearance between threaded end of the stop light switch and the stopper becomes 0.3 mm (0.012 in). Then, tighten the lock nut.

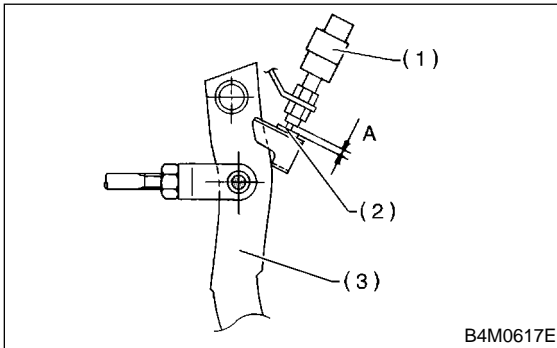

# GENERAL DIAGNOSTICS

Brake

## 21. General Diagnostics S405278

### A: INSPECTION S405278A10

#### 1. BRAKE SYSTEM S405278A1001

	Trouble and possible cause	Corrective action
<b>1. Insufficient braking</b>	(1) Fluid leakage from the hydraulic mechanism	Repair or replace (cup, piston seal, piston boot, master cylinder piston kit, pipe or hose).
	(2) Entry of air into the hydraulic mechanism	Bleed the air.
	(3) Excessively wide shoe clearance	Adjust the clearance.
	(4) Wear, deteriorated surface material, adhering water or fluid on the lining	Replace, grind or clean.
	(5) Improper operation of master cylinder, disc caliper, brake booster or check valve	Correct or replace.
<b>2. Unstable or uneven braking</b>	(1) Fluid on the lining, drum or rotor	Eliminate cause of fluid leakage, clean, or replace.
	(2) Drum or rotor eccentricity	Correct or replace the drum or rotor.
	(3) Worn brake drum, or damage to the drum caused by sand	Correct by grinding, or replace.
	(4) Improper lining contact, deteriorated surface material, improper inferior material, or wear	Correct by grinding, or replace.
	(5) Deformed back plate	Correct or replace.
	(6) Improper tire inflation	Inflate to correct pressure.
	(7) Disordered wheel alignment	Adjust alignment.
	(8) Loosened back plate or the support installing bolts	Retighten.
	(9) Loosened wheel bearing	Retighten to normal tightening torque or replace.
	(10) Trouble in the hydraulic system	Replace the cylinder, brake pipe or hose.
	(11) Uneven effect of the parking brake	Check, adjust, or replace the rear brake and cable system.
<b>3. Excessive pedal stroke</b>	(1) Entry of air into the hydraulic mechanism	Bleed the air.
	(2) Excessive play in the master cylinder push rod	Adjust.
	(3) Fluid leakage from the hydraulic mechanism	Repair or replace (cup, piston seal, piston boot, master cylinder piston kit, pipe or hose).
	(4) Improperly adjusted shoe clearance	Adjust.
	(5) Improper lining contact or worn lining	Correct or replace.
<b>4. Brake dragging or improper brake return</b>	(1) Insufficient pedal play	Adjust play.
	(2) Improper master cylinder return	Clean or replace the cylinder.
	(3) Clogged hydraulic system	Replace.
	(4) Improper return or adjustment of parking brake	Correct or adjust.
	(5) Weakened spring tension or breakage of shoe return spring	Replace the spring.
	(6) Excessively narrow shoe clearance	Adjust the clearance.
	(7) Improper disc caliper operation	Correct or replace.
	(8) Improper adjusted wheel bearing	Adjust or replace.
<b>5. Brake noise (1) (creak sound)</b>	(1) Hardened or deteriorated lining	Replace the shoe assembly or pad.
	(2) Worn lining	Replace the shoe assembly or pad.
	(3) Loosened back plate or the support installing bolts	Retighten.
	(4) Loose wheel bearing	Retighten to normal tightening torque.
	(5) Dirty drum or rotor	Clean the drum or rotor, or clean and replace the brake assembly.

# GENERAL DIAGNOSTICS

Brake

	Trouble and possible cause	Corrective action
<b>6. Brake noise (2) (hissing sound)</b>	(1) Worn lining	Replace the shoe assembly or pad.
	(2) Improper installed shoe or pad	Correct or replace the shoe assembly or pad.
	(3) Loose or bent drum or rotor	Retighten or replace.
<b>7. Brake noise (3) (click sound)</b>	In the case of the disc brake:	
	(1) Excessively worn pad or the support	Replace the pad or the support.
	In the case of the drum brake:	
	(1) Excessively worn shoe ridge	Replace the back plate.
	(2) Lack of oil on the shoe ridge surface and anchor	Add more grease.

## 2. HILL HOLDER S405278A1002

### CAUTION:

● Description in parentheses is a characteristic of hill holder and does not indicate abnormality.

Depressing force required for clutch pedal equipped to hill holder specifications is 20 to 29 N (2 to 3 kg, 4 to 7 lb) larger than the conventional specifications, which does not constitute abnormality.

● When vehicle cannot travel (brake cannot be released) because return spring is broken, remove adjust nut, disconnect clutch and PHV, and then return PHV lever to release the brake. (Be sure to apply the parking brake before starting this operation.)

● The hill holder may not be activated on a slope of an extremely small inclination.

	Trouble and possible cause	Corrective action
<b>1. Counterforce of clutch pedal is too strong.</b>	(1) PHV cable is damaged or does not operate properly.	Repair or replace.
	(2) Lever of PHV is defective.	Replace entire PHV assembly.
	(3) Clutch system is anomalous.	Replace clutch system.
<b>2. Vehicle does not stop on uphill road of 3° or higher inclination.</b>	(1) Front side of vehicle is lowered.	Replace suspension.
	(2) PHV cable is broken.	Replace.
	(3) Play of clutch is excessive.	Adjust.
	(4) PHV cable is elongated.	Adjust.
	(5) Sealing of PHV is poor.	Replace entire PHV assembly.
<b>3. Shock is felt when starting.</b>	(1) Poor adjustment of starting performance.	Adjust.
	(2) When depressing the brake pedal strongly:	(The stronger brake pedal depressing force, the later hill holder releases.)
	(3) When starting on flat road after stopping reverse movement:	(Because hill holder is activated.)
<b>4. Vehicle slips down when starting.</b>	(1) PHV cable is elongated.	Adjust.
	(2) Clutch facing is worn out.	Adjust or replace.
	(3) Bracket (cable) or stay (PHV) is deformed.	Repair or replace.
<b>5. Vehicle cannot start after stoppage.</b>	(1) Return spring is fatigued or broken.	Replace.
	(2) PHV lever won't return.	Replace entire PHV assembly.
	(3) When intentionally depressing brake pedal strongly:	[When the brake pedal is depressed by a force of 1,177 N (120 kgf, 265 lb) or more.]
<b>6. Abnormal sound is generated upon releasing brake pedal when stopping.</b>	(1) Rotor and pad matched with each other due to inadequate depressing force to brake pedal.	(Abnormal sound is not generated when depressing brake pedal a little stronger.)
<b>7. Abnormal sound is generated when operating clutch pedal.</b>	(1) Grease is inadequate for the hook of return spring and sliding portion of PHV cable end.	Apply grease.
	(2) When releasing after maintaining high fluid pressure:	(Flowing sound of fluid when releasing high fluid pressure.)
	(3) Clutch system is anomalous.	Replace clutch system.



# GENERAL DIAGNOSTICS

Brake

---

**MEMO:**